



Barocel 7045 Gauge

INSTRUCTION MANUAL

Copyright notice

©Edwards Limited 2019. All rights reserved.

Trademark credits

Edwards and the Edwards logo are trademarks of Edwards Limited, Innovation Drive, Burgess Hill, West Sussex RH15 9TW.

VCR® Swagelok Marketing Co.

Disclaimer

The content of this manual may change from time to time without notice. Edwards accepts no liability for any errors that may appear in this manual nor does it make any expressed or implied warranties regarding the content. So far as is reasonably practicable Edwards has ensured that its products have been designed and constructed so as to be safe and without risks when properly installed and used in accordance with Edwards operating instructions. Edwards accepts no liability for loss of profit, loss of market or any other indirect or consequential loss whatsoever.

Product warranty and limit of liability are dealt with in Edwards standard terms and conditions of sale or negotiated contract under which this document is supplied.

You must use the Barocel 7045 as described in this manual. Read this manual before you install, operate and maintain the Barocel 7045.

CE Declaration of Conformity

Edwards Ltd
Innovation Drive
Burgess Hill
West Sussex
RH15 9TW
UK

The following product

List products here including –

- Barocel 7025m Series Capacitance Manometer W6011*
- Barocel 7025 Series Capacitance Manometer W6021*
- Barocel 7045 Series Capacitance Manometer W6032*
- Barocel 7100 Series Capacitance Manometer W6033*

Is in conformity with the relevant requirements of European CE legislation:

2014/30/EU	Electromagnetic compatibility (EMC) directive
2011/65/EU	Restriction of certain hazardous substances (RoHS) directive as amended by Delegated Directive (EU) 2015/863

Based on the relevant requirements of harmonised standards:

EN 61010-1:2010	Safety requirements for electrical equipment for measurement, control and laboratory use. General requirements
EN 60529:1991 + A2:2013	Specification for degree of protection provided by enclosures (IP code) – IP code 30
EN 61326-1:2013	Electrical equipment for measurement, control and laboratory use. EMC requirements. General requirements Class B Emissions, Industrial Immunity

This declaration, based on the requirements of the listed Directives and EN ISO/IEC 17050-1, covers all product serial numbers from this date on: 6th June 2019.

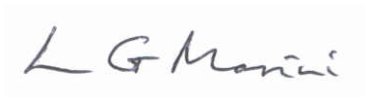

Larry Marini – Senior Technical Manager
Eastbourne



Andy Marsh – General Manager
Eastbourne

Additional Legislation and Compliance Information

EU RoHS Directive: Material Exemption Information

This product is compliant with no Annex III or IV Exemptions

EU REACH Regulation Compliance

This product is a complex article which is not designed for intentional substance release. To the best of our knowledge the materials used comply with the requirements of REACH. The product manual provides information and instruction to ensure the safe storage, use, maintenance and disposal of the product including any substance-based requirements.

Article 33 Declaration

This product does not knowingly or intentionally contain Candidate List Substances of Very High Concern above 0.1%ww by article as clarified under the 2015 European Court of Justice ruling in case C-106/14.

ADDITIONAL INFORMATION

材料成分声明

China Material Content Declaration



表示该有害物质在该部件的所有均质材料中的含量低于 GB/T 26572 标准规定的限量要求。
Indicates that the hazardous substance contained in all of the homogeneous materials for this part is below the limit requirement in GB/T 26572.

Contents

Introduction	7
Product identification	7
Intended use	7
Function	7
Before using this gauge	7
Safety symbols	8
Safety precautions	8
Liability and warranty	8
Technical data	9
Dimensions	11
Analogue measurement signal versus pressure	12
Installation	13
Vacuum connection	13
Electrical connection	14
D-Sub, 15-pin connector	15
Operation	16
Status indication	16
To zero the gauge	16
<ZERO> Adjustment	17
<ZERO> Adjustment with ramp function	18
Switching functions	19
Adjusting the setpoints	20
To activate the factory setpoint (factory reset)	21
Uninstallation	22
Maintenance and repair	23
Return the equipment for service	24
Disposal	25
Separating the components	25

This page has been intentionally left blank.

List of Figures

Figure 1: Dimensions	11
Figure 2: Analogue measurement signal versus pressure	12
Figure 3: Connect the gauge to the system	14
Figure 4: D-Sub 15-pin sensor cable	15
Figure 5: Measurement signal (pressure p)	20

List of Tables

Table 1: General	9
Table 2: Output signal	9
Table 3: Gauge identification	9
Table 4: Switching functions	9
Table 5: Status relay	10
Table 6: Diagnostic port	10
Table 7: Electrical	10
Table 8: Materials exposed to vacuum	11
Table 9: Environmental	11

Introduction

Product identification

Specify the information given on the gauge nameplate in all communications with Edwards.

Intended use

The Barocel 7045 gauge is intended for absolute pressure measurement of gases in their respective pressure ranges, see [Technical data](#) on page 9.

The gauges belong to the Barocel 7000 series and can be operated in connection with an Edwards vacuum gauge controller or another applicable unit.

Function

A ceramic diaphragm is deflected by pressure. The deflection is measured capacitively and converted into an analogue linear output signal by the digital electronics.

The output signal is independent of the gas type.

Very accurate pressure measurement is achieved by the sensor being heated to a constant temperature of 45 °C which results in a compensation of changes in the ambient conditions and a reduced deposition of process products and by-products in process applications.

Before using this gauge

Make sure that the model is the same as you ordered and there was no damage during shipment.

Read this instruction manual before you install, operate, inspect, or service this gauge to familiarize yourself with safety precautions, specifications and operations.

Safety symbols

Important safety information is highlighted as WARNING and CAUTION instructions. Obey the safety instructions.

The use of warnings and cautions is defined as:



WARNING:

Warnings are given where failure to obey the instruction could result in injury or death to people. The symbol shown will change and refer to the applicable hazard.



CAUTION:

Cautions are given where failure to obey the instruction could result in minor injury or damage to the equipment, associated equipment or process.

Safety precautions

- Obey the applicable regulations and follow the necessary precautions for the process media used. Reactions with the gauge materials are possible.
- Obey the applicable regulations and follow the necessary precautions for the work you do. Obey the safety instructions in this document.
- Before you start work, find out if any vacuum components are contaminated. Obey the applicable regulations and the necessary precautions when you handle contaminated parts.

Ensure all other users are aware of the safety instructions.

Liability and warranty

Edwards accepts no liability and the warranty becomes non applicable if the end user or third parties:

- Ignore the information in this document
- Use the gauge in a non-agreeable manner
- Make any kind of interventions (modifications, alterations, etc.) on the gauge
- Use the gauge with accessories not listed in this instruction manual.

The customer assumes the responsibility along with the process media used.

Gauge failures because of contamination are not included in the warranty.

Technical data

Table 1 General

Measurement range	→ "Validity"
Accuracy*	0.15% of reading
Temperature effect on zero	
0.1 F.S.	0.0050% F.S./ °C
1.0 to 1100 F.S.	0.0025% F.S.
Temperature effect on span	0.01% of reading /°C
Resolution	0.003% F.S.
Gas type dependence	None
Mass	837 to 897 grams

* Non linearity, hysteresis, repeatability at 25 °C ambient operating temperature without temperature effects after operation of 2 hours.

Table 2 Output signal

Output signal analogue (measurement signal)	
Voltage range	-5 to +10.24 V (limited to +10.24 V)
Measurement range	0 to +10 V
Relationship voltage-pressure	Linear
Output impedance	0 Ω (short-circuit proof)
Loaded impedance	> 10 kΩ
Response time*	
≥ 0.25 Torr/mbar (F.S.)	30 ms
0.1 Torr/mbar (F.S.)	130 ms

* Increase 10 to 90% F.S.R.

Table 3 Gauge identification

Resistance R_{ident} Voltage	Resistance 13.2 kΩ referenced to supply common ≤ 5 V
-----------------------------------	--

Table 4 Switching functions

Switching functions	SP1, SP2
Setting range	0 to 99% F.S. (0 to 9.9 volts)
Hysteresis	1% F.S.
Relay contact	30 V d.c. / ≤ 0.5 A (d.c.) floating (n.o.)
Closed	$p \leq p_{sp}$ (LED is illuminated)
Open	$p \geq p_{sp}$ (LED is not illuminated)
Switching time	≤ 50 ms

Table 5 Status relay

Status relay	
Relay contact	30 V (d.c.) / ≤ 0.5 A (d.c.) connected to supply common (pin 5)
Closed	Measurement mode
	Warning
Open	No supply voltage
	Warming up
	Error

Table 6 Diagnostic port

Diagnostic port	Jack connector, 2.5 mm, 3-pin
-----------------	-------------------------------

**WARNING: HIGH VOLTAGE**

Risk of electrical shock. The gauge can only be connected to power supplies, instruments or control devices that comply with the requirements of a grounded Protective Extra-Low Voltage (PELV) and Limited Power Source (LPS), Class 2. The connection to the gauge has to be fused*.

* Edwards controllers meet this requirement.

Table 7 Electrical

Supply voltage	Class 2 / LPS
at the gauge	+14 to +30 V d.c. or ± 15 V ($\pm 5\%$)
ripple	≤ 1 V _{pp}
Power consumption	
while being heated	≤ 12 W
at operating temperature	≤ 8 W
Electrical connection*	15-pin D-Sub, male
Sensor cable	15-pin plus shielding
Cable length [§]	
Supply voltage 15 V	≤ 8 m (0.14 mm ² /conductor) ≤ 15 m (0.25 mm ² /conductor)
Supply voltage 24 V	≤ 43 m (0.14 mm ² /conductor) ≤ 75 m (0.25 mm ² /conductor)
Supply voltage 30 V	≤ 88 m (0.14 mm ² /conductor) ≤ 135 m (0.25 mm ² /conductor)
Grounding concept	See Electrical connection on page 14

* The gauge is protected against reverse polarity of the supply voltage and overload.

[§] For longer cables, larger conductor cross-sections are required ($R_{cable} \leq 1.0 \Omega$).

Table 8 Materials exposed to vacuum

Materials exposed to vacuum	Ceramics ($Al_2O_3 \geq 99.5\%$), Stainless steel AISI 316L
Internal volume	$\leq 4.2 \text{ cm}^3$
Admissible pressure (absolute)	
1000/1100 F.S.	4 bar 400 kPa
1/10/100 F.S.	2.6 bar 260 kPa
0.1 F.S.	1.3 bar 130 kPa
Bursting pressure (absolute)	6 bar 600 kPa

Table 9 Environmental

Admissible temperatures	
Storage	-40 °C to +65 °C
Operation	+10 °C to +40 °C
Bake-out	$\leq 110 \text{ °C}$ at the flange
Relative humidity	$\leq 80\%$ at temperatures $\leq +31 \text{ °C}$ decreasing to 50% at +40 °C
Use	Indoors only, altitude up to 2000 metres NN
Degree of protection	IP 40

Dimensions

Figure 1 Dimensions (mm)

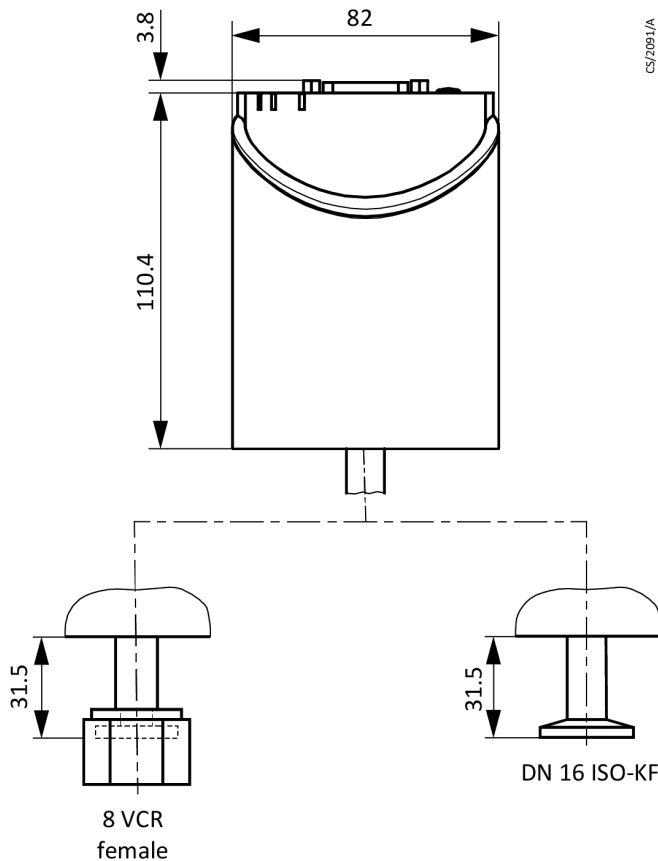

Analogue measurement signal versus pressure

Figure 2 Analogue measurement signal versus pressure

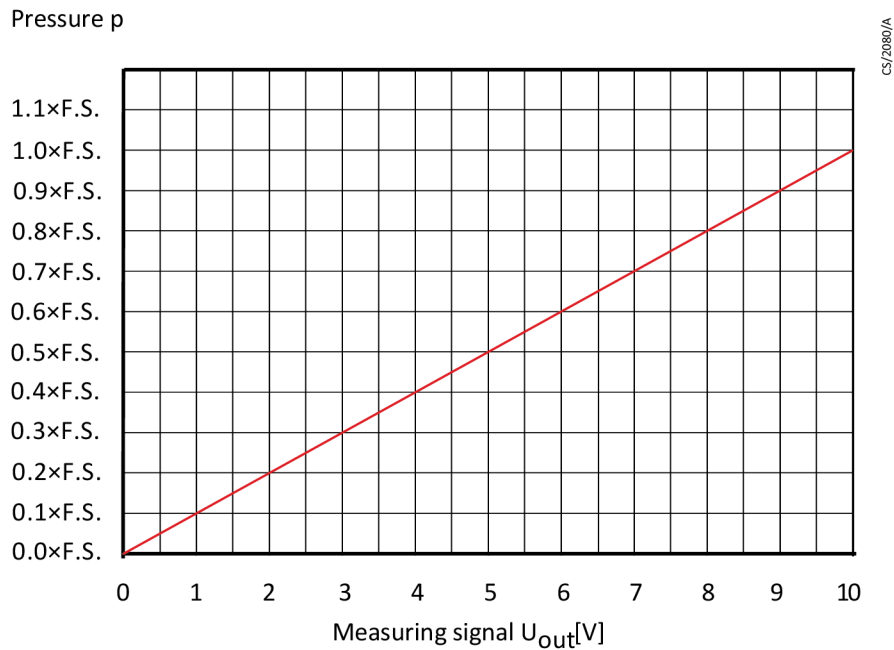

$$p = (U_{out} / 10 \text{ V}) \times p (\text{F.S.})$$

Conversion Torr to Pascal

Torr	mbar	Pa
1.00	$1013.25 / 760 = 1.3332\dots$	$101325 / 760 = 133.3224\dots$

Example: Gauge with 10 Torr F.S.
Measurement signal $U_{out} = 6 \text{ V}$

$$p = (6 \text{ V} / 10 \text{ V}) \times 10 \text{ Torr}$$

$$= 0.6 \times 10 \text{ Torr} = 6 \text{ Torr}$$

Installation



WARNING: NOT FAIL-SAFE DESIGNED

Risk of death. Do not use the Barocel 7045 for safety critical applications. The gauge is not intended to be fail-safe.



CAUTION: IMPACT DAMAGE

Risk of damage to equipment. The ceramic sensor can be damaged by impacts. Do not drop the gauge.

Vacuum connection



WARNING: PRESSURIZED CONTAINER

Risk of injury or death. A release of parts and process gases because of system overpressure greater than 1 bar causes a hazard. Do not open any clamps while the vacuum system is pressurized. Use clamps designed for overpressure conditions.



WARNING: PRESSURIZED CONTAINER

Risk of injury or death. A release of process gases because of system overpressure greater than 2.5 bar causes a hazard. KF flange connections with elastomer seals cannot resist such pressures. Use O-rings with an outer centring ring.



WARNING: HIGH VOLTAGE

Risk of electric shock. Make sure that the pump and electrical cables are correctly protected against earth (ground) faults. A protective earth (ground) conductor (equivalent or larger than the incoming supply power cable conductor) must be attached to the protective earth (ground) stud.



CAUTION: DIRT CONTAMINATION

Risk of damage to equipment. Dirt and damage will cause the gauge to operate incorrectly. When you handle the gauge, prevent dirt and damage to the vacuum components.



CAUTION: DIRT SENSITIVE AREA

Dirt sensitive area. Do not touch the components with bare hands as it increases the desorption rate. Wear clean, lint-free gloves and use clean tools when you work in this area.

1. Position the gauge to prevent vibrations.

 **Note:**

The gauge can be installed in any orientation. We recommend you install the gauge in a horizontal to upright position and use a seal with a centring ring and filter to prevent the influx of condensates and particles in the measurement chamber.

2. Install the gauge so that the buttons can be accessed with a pin for future adjustments.
3. Remove the protective lid and connect the gauge to the vacuum system.
4. Keep the protective lid.

Figure 3 Connect the gauge to the system

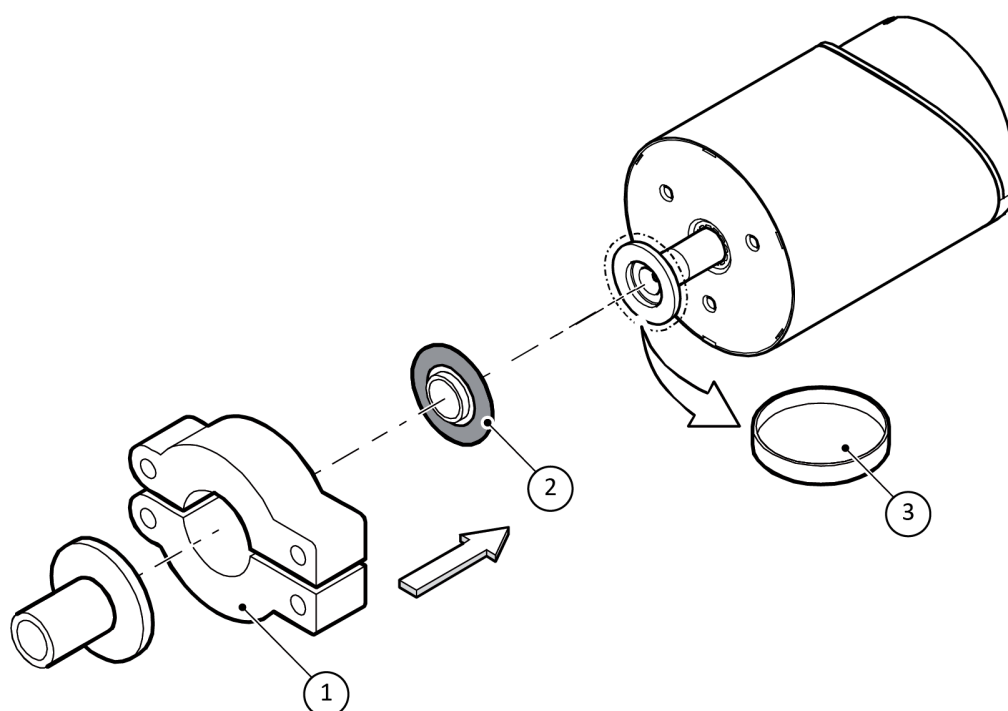

1. Clamp
2. Seal with centring ring
3. Protective lid

CS/2092/A

Electrical connection



WARNING: HIGH VOLTAGE

Risk of electric shock. The gauge can only be connected to power supplies, instruments or control devices that agree to the requirements of a grounded Protective Extra-Low Voltage (PELV) and Limited Power Source (LPS), Class 2. The connection to the gauge has to be fused.*

* Edwards controllers meet this requirement.

Make sure that the vacuum connection is correct.

Ground loops, differences of potential, or EMC problems can affect the measurement signal. For optimum signal quality:

- Use an overall metal braided shielded cable. The connector must have a metal case.
- Connect the cable shield to ground on one side through the chassis ground. Do not connect the other side of the shield.
- Connect the supply common with protective ground directly at the power supply.
- Use differential measurement input (signal common and supply common wired separately).
- Potential difference between the supply common and the housing ≤ 18 V (over-voltage protection).

D-Sub, 15-pin connector

If a sensor cable is not available, one can be made. Refer to [Figure 4](#) on page 15. Connect the sensor cable.

Figure 4 D-Sub 15-pin sensor cable

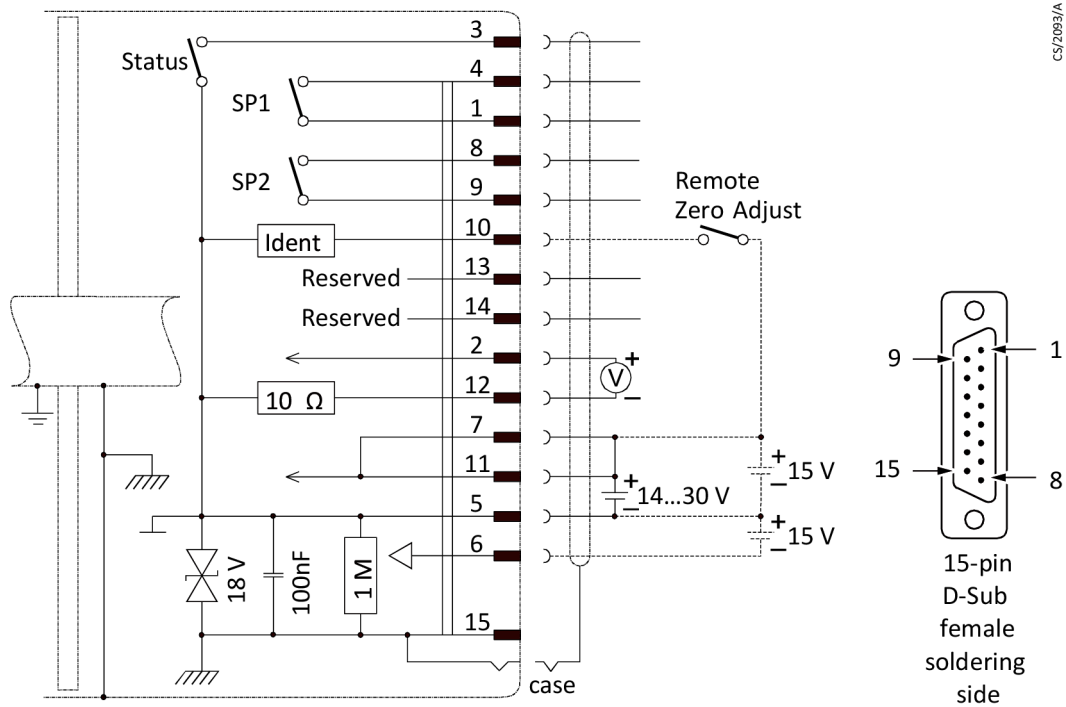

- | | |
|--|---|
| 1, 4 Relay SP1, closing contact | 10 Gauge identification or remote zero adjust |
| 2 Signal output (measurement signal) or thresholds SP1/2 | 12 Signal common |
| 3 Status | 13 Reserved |
| 5 Supply common | 14 Reserved |
| 6 Supply (-15 V) | 15 Housing (chassis ground) |
| 7, 11 Supply (+14 to +30 V or +15 V) | case Connector case |
| 8, 9 Relay SP2, closing contact | |

Operation

Put the gauge into operation. If you use an Edwards controller, specify the measurement range and the unit of measurement.

Warm-up time:

- For general purpose reading (within specifications) > 0.50 hours
- For zero adjustment and precision measurement > 2.00 hours

 **Note:**

If the gauge is used for fast downstream pressure control, we recommend setting the signal filter to "fast".

The filter can be set via the diagnostic port.

Status indication

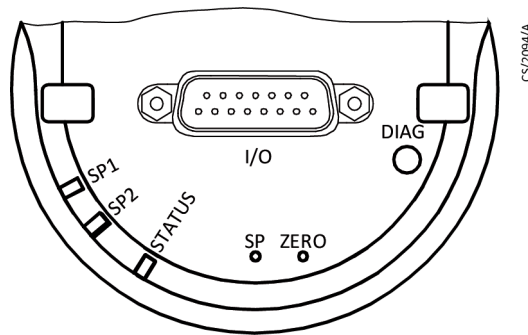

LED	Status	Meaning
<STATUS>	off	No supply voltage
	Illuminated	Measurement mode
	Flashing green	
	Short blinks	Warning, over/under range
	Long blinks	Warming up
	Illuminated solid red	Error
<SP1>	Illuminated solid green	$p \leq$ setpoint 1
	Flashing green	Waiting for setpoint 1 input
	Off	$p >$ setpoint 1
<SP2>	Illuminated solid green	$p \leq$ setpoint 2
	Flashing green	Waiting for setpoint 2 input
	Off	$p >$ setpoint 2

To zero the gauge

The gauge is factory calibrated in an upright orientation.

 **Note:**

Do a zero adjustment when the gauge is operated for the first time.

Continuous operation or contamination can lead to zero drift and the gauge will need zero adjustment.

To adjust the zero, operate the gauge under the same constant ambient conditions and in the same mounting orientation as normal.

The output signal is dependent on the mounting orientation. The signal difference between the vertical and horizontal mounting orientation is:

F.S.	$\Delta U/90^\circ$
1000 Torr/mbar	approximately 2 mV
100 Torr/mbar	approximately 10 mV
10 Torr/mbar	approximately 50 mV
1 Torr/mbar	approximately 300 mV
0.1 Torr/mbar	approximately 1.8 V

 **Note:**

If the gauge is operated through a controller, the zero of the whole measurement system has to be adjusted on the controller. Adjust the zero on the gauge first and then on the controller.

<ZERO> Adjustment

The zero can be adjusted by:

- The <ZERO> button on the gauge
- The digital input "Remote Zero": Apply the supply voltage to pin 10 (15-pin) or to pin 7 (9-pin) pulse.
- An Edwards vacuum gauge controller.

 **Note:**

While the gauge is being heated and/or under atmospheric pressure, the zero adjustment function is disabled to prevent operational errors.

To adjust the zero:

1. Evacuate the gauge to a pressure according to the table below:

F.S.	Recommended final pressure for zero adjustment		
1100 mbar	-	$< 6.65 \times 10^0$ Pa	$< 6.65 \times 10^{-2}$ mbar
1000 Torr	$< 5.0 \times 10^{-2}$ Torr	$< 6.65 \times 10^0$ Pa	-
100 Torr/mbar	$< 5.0 \times 10^{-3}$ Torr	$< 6.65 \times 10^{-1}$ Pa	$< 6.65 \times 10^{-3}$ mbar
10 Torr/mbar	$< 5.0 \times 10^{-4}$ Torr	$< 6.65 \times 10^{-2}$ Pa	$< 6.65 \times 10^{-4}$ mbar
1 Torr/mbar	$< 5.0 \times 10^{-5}$ Torr	$< 6.65 \times 10^{-3}$ Pa	$< 6.65 \times 10^{-5}$ mbar
0.1 Torr/mbar	$< 5.0 \times 10^{-6}$ Torr	$< 6.65 \times 10^{-4}$ Pa	$< 6.65 \times 10^{-6}$ mbar

 **Note:**

If the final pressure in the gauge is too high for the zero adjustment ($> 25\%$ of the F.S.), the zero cannot be reached and the <STATUS> flashes green. If this happens, start the factory setting and adjust the zero again.

2. Operate the gauge for a minimum of 0.25 hours (until the signal is stable).

- Briefly press the <ZERO> button with a pin (maximum $\varnothing 1.1$ mm). The zero adjustment runs automatically. The <STATUS> LED flashes until the adjustment (duration ≤ 8 seconds) is completed.

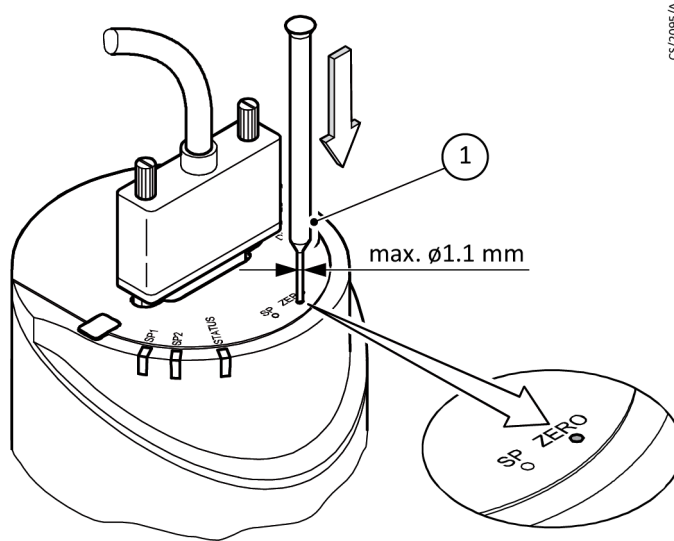

- Press the button briefly

Note:

After zero adjustment, the gauge automatically returns to measurement mode.

The <STATUS> LED flashes if:

- At final pressure, the signal output is negative (< -20 mV)
- The zero adjustment has failed.

<ZERO> Adjustment with ramp function

The ramp function allows to adjust the zero at a known reference pressure within the measurement range of the gauge.

It also permits to adjust an offset of the characteristic curve to:

- Compensate for the offset of the measurement system, or
- Obtain a slightly positive zero for a 0 to 10 V AD converter.

The offset should not be more than 2% of the F.S. (+200 mV). The measurement range is more than the upper limit if there is a higher positive offset.

Note:

Zero adjustment using the ramp function can be done by the <ZERO> button on the gauge.

The recommended procedure for adjusting the offset of a measurement system is:

- Operate the gauge for at least 1.0 hour (until the signal is stable).
- Push the <ZERO> button with a pin (maximum $\varnothing 1.1$ mm) and keep it depressed. The <STATUS> LED starts flashing. After 5 seconds, the zero adjustment value, starting at the current output value, keeps continually changing (ramp) until the button is released or until the setting limit (maximum 25% F.S.) is reached. The corresponding output signal is delayed by about 1 second.

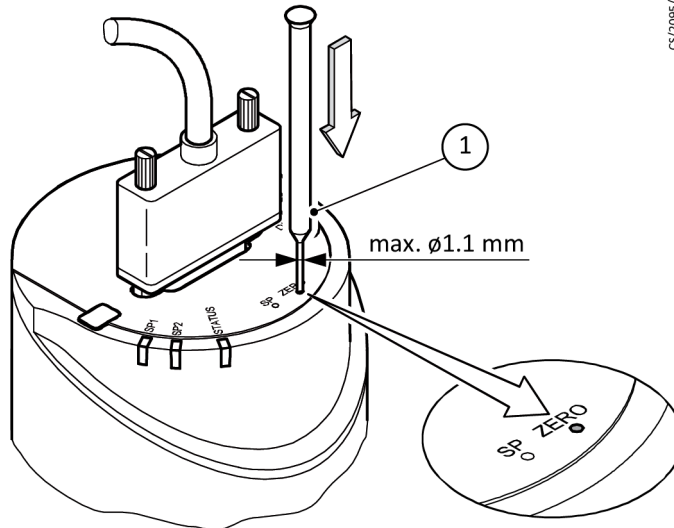

1. Keep the button depressed

3. Push the <ZERO> button again for:

Fine adjustment within 0 to 3 seconds: The zero adjustment value changes by one unit (push <ZERO> button in 1 second intervals).

Change of direction within 3 to 5 seconds: The zero adjustment changes its direction (the blinking frequency of the <STATUS> LED changes briefly).

Note:

If the <ZERO> button is released for more than 5 seconds, the gauge returns to the measurement mode.

The <STATUS> LED flashes green if the signal output is negative (< -20 mV).

Switching functions

The two switching functions can be adjusted to any pressure within the measurement range.

The current setpoint setting:

- Is output at the D-Sub connector instead of the measurement signal and can be measured with a voltmeter after the <SP> button is pressed.

If the pressure is lower than the setpoint, the corresponding LED is lit (<SP1> or <SP2>) and the corresponding relay is energized.

Figure 5 Measurement signal (pressure p)

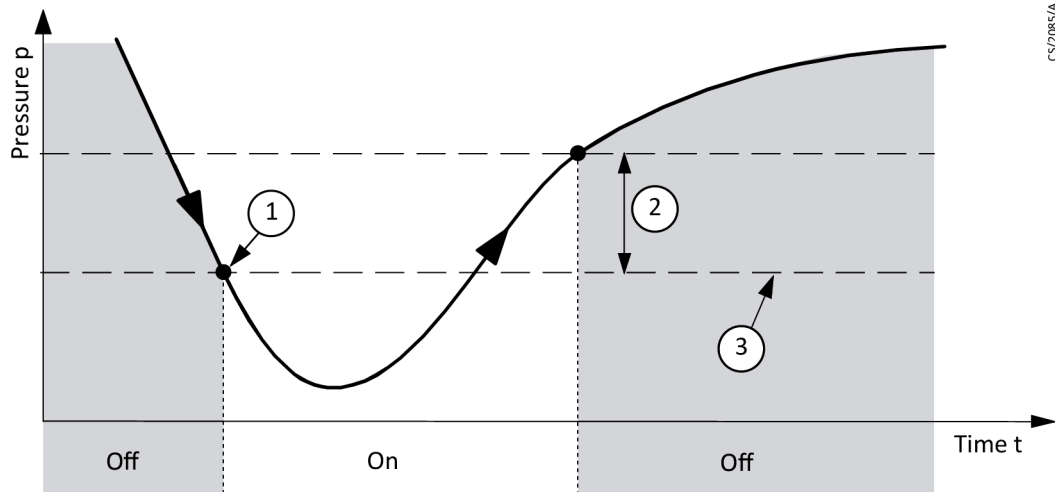

1. Setpoint
2. Hysteresis
3. Threshold value

Adjusting the setpoints



CAUTION: DAMAGE TO THE EQUIPMENT

Risk of malfunction. If processes are controlled by the signal output, by pushing the <SP> button, the measurement signal is suppressed and the corresponding threshold value is output instead. Push the <SP> button only if you are sure that no malfunction will occur.

The setpoints can be adjusted by the buttons on the gauge.

Adjusting setpoint <1>

1. Push the <SP> button with a pin (maximum $\varnothing 1.1$ mm). The gauge changes to the switching function mode and outputs the current lower threshold value at the measurement value output for approximately 10 seconds (LED <1> blinks).

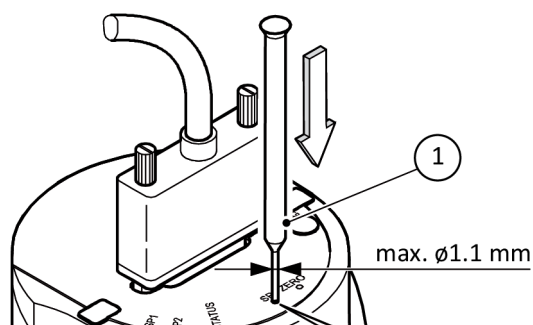

1. Press the button

2. To change the threshold value, push the <ZERO> button and keep it depressed. The threshold keeps changing from the current value (ramp) until the button is released or until you get to the limit of the setting range.

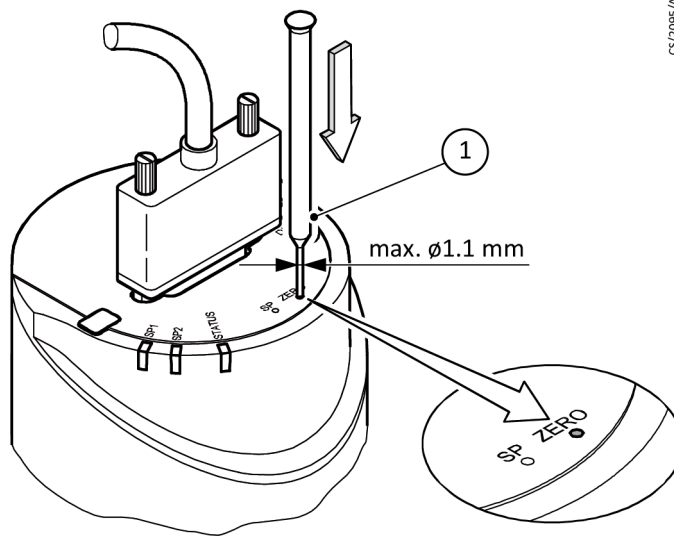

1. Keep the button depressed

3. Push the <ZERO> button again for:

Fine adjustment within 0 to 3 seconds: the zero adjustment value changes by one unit

Change of direction within 3 to 5 seconds: the zero adjustment changes its direction (the blinking frequency of the <STATUS> LED changes briefly)

Note:

If the <ZERO> button is released for more than 5 seconds, the gauge returns to the measurement mode.

The upper threshold is automatically set at 1% F.S. above the lower one (hysteresis).

Adjusting setpoint <2>

Push the <SP> button twice (LED <2> blinks). The adjustment procedure is the same as for setpoint <1>.

To activate the factory setpoint (factory reset)

All user defined parameters (for example, zero, filter) are restored to their default values.

Note:

The default parameters are irreversible once loaded.

To load the default parameters:

1. Remove the gauge from operation.
2. Keep the <ZERO> button depressed for a minimum of 5 seconds while the gauge is being put into operation (Power ON).

Uninstallation



WARNING: CONTAMINATED PARTS

Risk to health and the environment from contaminated parts. Before you start work, find out if any parts are contaminated. Obey the relevant regulations and follow the necessary precautions when handling contaminated parts.



CAUTION: IMPACT DAMAGE

Risk of damage to equipment. The ceramic sensor can be damaged by impacts. Do not drop the gauge.



CAUTION: DIRT CONTAMINATION

Risk of damage to equipment. Dirt and damage will cause the gauge to operate incorrectly. When you handle the gauge, prevent dirt and damage to the vacuum components.



CAUTION: DIRT SENSITIVE AREA

Dirt sensitive area. Do not touch the components with bare hands as it increases the desorption rate. Wear clean, lint-free gloves and use clean tools when working in this area.

To uninstall the gauge:

1. Vent the vacuum system.
2. Remove the gauge from operation.
3. Unfasten the lock screws and disconnect the sensor cable.
4. Remove the gauge from the vacuum system and install the protective lid.

Maintenance and repair

Under clean operating conditions, the gauge requires no maintenance.

 **Note:**

The warranty does not include gauge failures that result from contamination.

We recommend that you check the zero at regular intervals.

Edwards accepts no liability and the warranty becomes non applicable if the end user or third parties do repair work.

Return the equipment for service

Before you send your equipment to us for service or for any other reason, you must send us a completed Declaration of Contamination of Vacuum Equipment and Components – Form HS2. The HS2 form tells us if any substances found in the equipment are hazardous, which is important for the safety of our employees and all other people involved in the service of your equipment. The hazard information also lets us select the correct procedures to service your equipment.

We provide instructions for completing the form in the Declaration of Contamination of Vacuum equipment and Components – Procedure HS1.

Download the latest documents from www.edwardsvacuum.com/HSForms/, follow the procedure in HS1, fill in the electronic HS2 form, print it, sign it, and return the signed copy to Edwards.

 **Note:**

If we do not receive a completed HS2 form, your equipment cannot be serviced.

Disposal



WARNING: CONTAMINATED PARTS

Risk to health and the environment from contaminated parts. Before you dispose of the gauge, find out if any parts are contaminated. Obey the relevant regulations and observe the necessary precautions when handling contaminated parts.



WARNING: ENVIRONMENTAL POLLUTANT

Risk to environment from substances or parts. The gauge and associated parts (mechanical and electric components, operating fluids, etc.) can be dangerous to the environment. Dispose of substances and parts in accordance with local regulations.

Separating the components

After the gauge is disassembled, separate its components by:

Contaminated components

Contaminated components (radioactive, toxic, caustic or biological hazard, etc.) must be decontaminated in accordance with national regulations, separated by its materials, and disposed of.

Non contaminated components

Non contaminated components must be separated by material and then recycled.

