

Instruction Manual

Active Strain Gauge

Description	Item Number
ASG2-1000-1/8 NPT	D357-35-000
ASG2-1000-NW16	D357-36-000
ASG2-2000-1/8 NPT	D357-37-000
ASG2-2000-NW16	D357-38-000





Declaration of Conformity

We, Edwards Limited,
Crawley Business Quarter,
Manor Royal,
Crawley,
West Sussex, RH10 9LW, UK

declare under our sole responsibility, as manufacturer and person within the EU authorised to assemble the technical file, that the product(s)

Active Strain Gauge 2	
ASG2-1000-1/8 NPT	D357-35-000
ASG2-1000-NW16	D357-36-000
ASG2-2000-1/8 NPT	D357-37-000
ASG2-2000-NW16	D357-38-000

to which this declaration relates is in conformity with the following standard(s) or other normative document(s)

EN61326-2-3: 2013 (Class B Emissions, Basic Immunity)	Electrical equipment for measurement, control and laboratory Use. EMC requirements. Particular requirements. Test configuration, operational conditions and performance criteria for transducers with integrated or remote signal conditioning
EN50581:2012	Technical Documentation for the Assessment of Electrical and Electronic Products with respect to the Restriction of Hazardous Substances

and fulfils all the relevant provisions of

2014/30/EU	Electromagnetic Compatibility (EMC) Directive
2012/19/EU	Waste from Electrical and Electronic Equipment (WEEE) Directive
2011/65/EU	Restriction of Certain Hazardous Substances (RoHS) Directive

Note: This declaration covers all product serial numbers from the date this Declaration was signed onwards.

Larry Marini, Senior Technical Manager

15.07.2015, Eastbourne

Date and Place

This product has been manufactured under a quality management system certified to ISO 9001:2008

Contents

Section	Page
1 Introduction	1
1.1 Scope of this manual	1
1.2 Description	1
1.3 Gas dependency	1
2 Technical data	3
2.1 Mechanical data	3
2.2 Performance, operation and storage conditions	3
2.3 Electrical data	4
2.4 Material exposed to vacuum	4
3 Installation	5
3.1 Unpack and inspect	5
3.2 Fit the ASG2 to the vacuum system	5
3.3 Electrical connections	5
3.3.1 Connect to Edwards controller	5
3.3.2 Connect to your own supply and control equipment	5
4 Operation	9
4.1 Pressure measurement	9
5 Maintenance	11
5.1 Zero adjustment	11
5.2 Cleaning	12
6 Storage and disposal	13
6.1 Storage	13
6.2 Disposal	13
7 Spares and accessories	15
7.1 Introduction	15
7.2 Accessories	15

For return of equipment, complete the HS Forms at the end of this manual.

Illustrations

Figure	Page
1 General views of ASG2	2
2 Dimensions of ASG2	4
3 Pins on the ASG2 (viewed from above)	6
4 Pins on the ASG2 adapter cable socket	6
5 Schematic diagram of typical electrical connections using 4 pin DIN connector	7
6 Schematic diagram of typical electrical connections using the ASG2 adapter cable	7
7 Zero and span setting detail	11

gea/0212/07/12

Tables

Table	Page
1 Zeroing pressure	11

1 Introduction

1.1 Scope of this manual

This manual provides installation, operation and maintenance instructions for the Edwards ASG2 (Active Strain Gauge). You must use the ASG2 as specified in this manual.

Read this manual before you install and operate the ASG2. Important safety information is highlighted as WARNING and CAUTION instructions; you must obey these instructions. The use of WARNINGS and CAUTIONS is defined below.



WARNING

Warnings are given where failure to observe the instruction could result in injury or death to persons.

CAUTION

Cautions are given where failure to observe the instruction could result in damage to the equipment, associated equipment or process.

The unit used through this manual conforms to the SI international system of units of measurement.

The following symbols appear on the ASG2:



Warning - refer to accompanying documentation.



Edwards offers European customers a recycling service.

1.2 Description

The ASG2, shown in [Figure 1](#), is a strain gauge. The measurement range of the ASG2-1000 is 1000 to 1 mbar. The range of the ASG2-2000 is 2000 to 1 mbar.

The ASG2 requires a 12 to 32 V d.c. power supply: it has a 0 to 10 V d.c. linear analogue output which is related to pressure. The ASG2 is compatible with all of the Edwards TICs (Turbo/Instrument Controllers), with the ADD (Active Digital Display) and with the enhanced ADC (Active Digital Controller). Alternatively, you can use an independent power supply for the ASG2 and can read the ASG2 output signal with a voltmeter or an analogue-to-digital converter. A standard Active gauge cable plus an ASG2 adapter cable are used to connect the Edwards controller. These are available as accessories (refer to [Section 7.2](#)). To connect to an electrical supply and voltmeter, the 4-way connector on the gauge head can be used.

A gauge identification signal is incorporated in the adapter cable: this is used by Edwards controllers to identify which type of active gauge is connected.

1.3 Gas dependency

The pressure sensing technique depends on the deflection of a metal diaphragm. The measurement is therefore completely independent of gas type.

Figure 1 - General views of ASG2

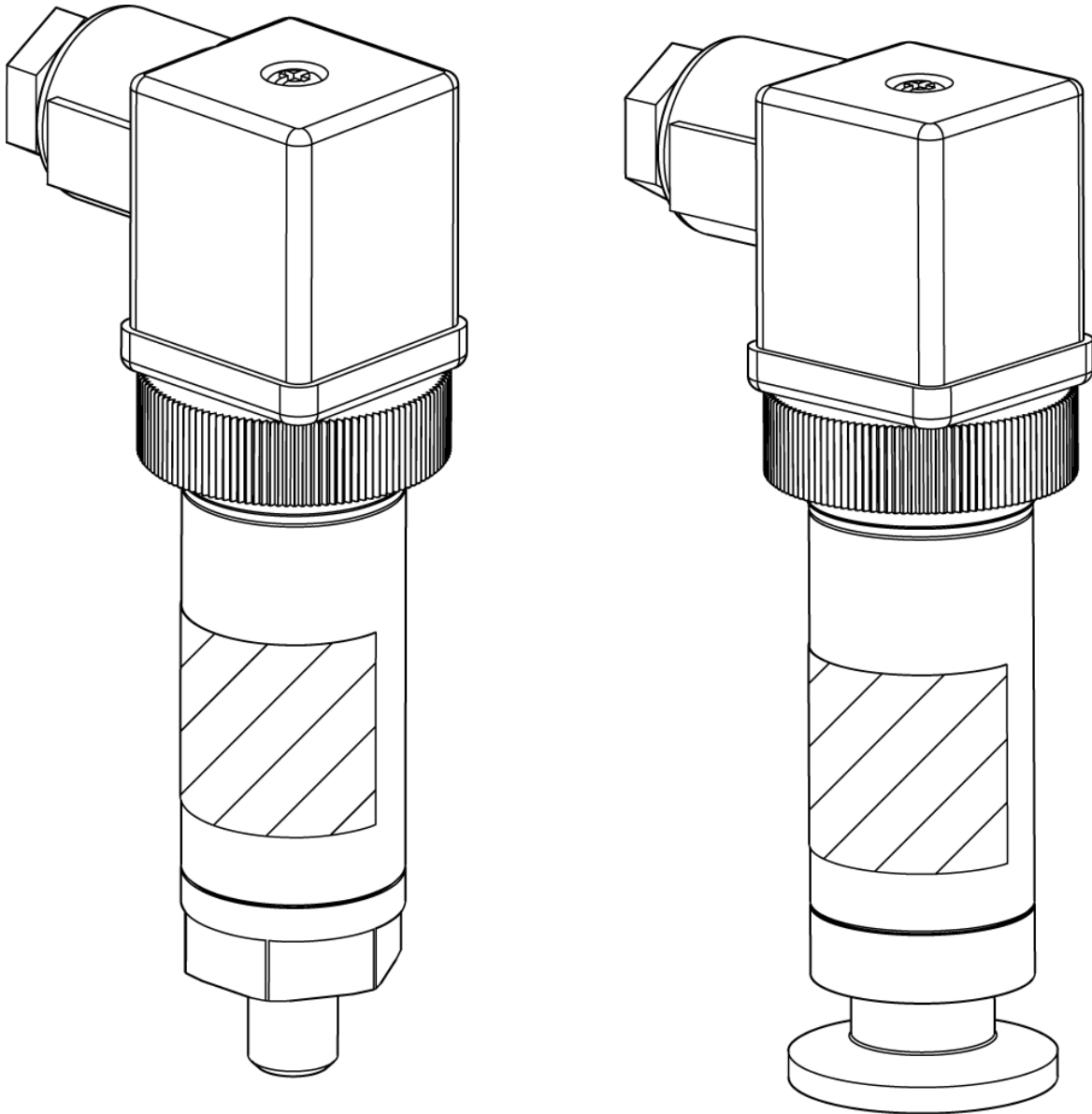

gea/0097/07/12

2 Technical data

2.1 Mechanical data

Dimensions	See Figure 2
Mass	0.15 kg (NW16) 0.13 kg (1/8" NPT)
Volume of gauge tube	
NW16	2.78 cm ³
1/8 inch NPT	2.74 cm ³
Enclosing rating	IP65

2.2 Performance, operation and storage conditions

Ambient temperature	
operation	-40 to +80 °C
storage	-40 to +80 °C
Compensated temperature	-10 to +50 °C
Ambient humidity (operating)	10 to 90% (non-condensing)
Pressure containment	200 bar
Maximum over pressure	4 x full scale with negligible calibration change
Pressure range	
ASG2-1000	1000 to 1 mbar
ASG2-2000	2000 to 1 mbar
Accuracy	± 0.2% full scale
Stability	0.1% full scale per year
Temperature co-efficient	0.03% full scale per °C

2.3 Electrical data

Note: The relationship between the output signal voltage and the pressure is linear with 10 V corresponding to the full scale of the gauge (e.g. for 1000 mbar full scale gauge 10 V is equivalent to 1000 mbar, 1 V is equivalent to 100 mbar, 0.1 V is equivalent to 10 mbar etc).

Electrical supply	
Voltage	12 to 32 V d.c.
Maximum power	0.1 W
Electrical connector	DIN 43650 Form A
Pressure output signal	
Nominal range	$0 \leq \text{output} \leq 10 \text{ V d.c.}$
Impedance	51 Ω
Min load	>10 k Ω

2.4 Material exposed to vacuum

Stainless Steel 316L
Hastelloy C276

Figure 2 - Dimensions of ASG2

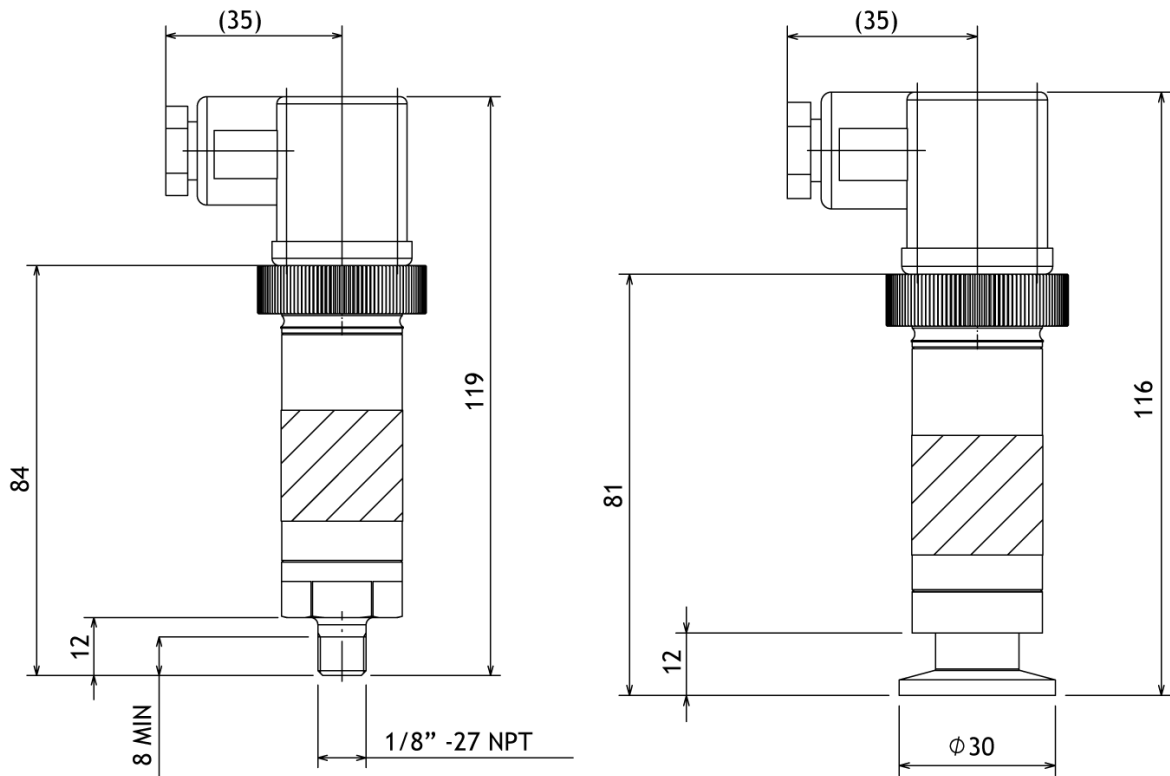

gesa/0098/07/12

3 Installation

3.1 Unpack and inspect

Remove all packing material and protective covers and check the ASG2.

If the ASG2 is damaged, notify your supplier and the carrier in writing within three days; state the Item Number of the ASG2 together with your order number and your supplier's invoice number. Retain all packing materials for inspection. Do not use the ASG2 if it is damaged.

If the ASG2 is not to be used immediately, replace the protective covers. Store the ASG2 in suitable conditions as described in Section 6.

3.2 Fit the ASG2 to the vacuum system



WARNING

Do not use o-ring/centring rings above atmospheric pressure. A coseal should be used instead.

The ASG2 can be mounted in any orientation. To avoid the build-up of debris or condensable material in the body tube of the ASG2 we recommend that you install the ASG2 vertically as shown in Figure 2.

To connect the ASG2 to your vacuum system:

- Use an O-Ring / centring ring or Co-seal and clamp to connect an NW16 flange to a similar flange on the vacuum system.
- Use a stepped O-Ring carrier or Co-seal to connect an ASG2 with a NW16 flange to a NW10 flange.
- Use PTFE tape for 1/8 inch NPT connection.

3.3 Electrical connections



WARNING

If the ASG2 malfunctions, the ASG2 pressure output may be incorrect. If such a failure could cause injury to persons or damage equipment, you must install a suitable control system to indicate the failure and, if necessary, to close down your process system.

3.3.1 Connect to Edwards controller

Connect the ASG2 to the controller using an adapter cable and an active gauge cable (refer to Section 7).

3.3.2 Connect to your own supply and control equipment

Note: Do not connect the electrical supply common to the signal common. If you do, the ASG2 output signal will be inaccurate.

If connection is to be made using the 4 pin DIN connector, the pin allocations are as shown in Figure 3.

Pin number	Use
1	Electrical supply positive voltage
2	Electrical supply common
3	Pressure measurement output signal
4	Output common

Figure 3 - Pins on the ASG2 (viewed from above)

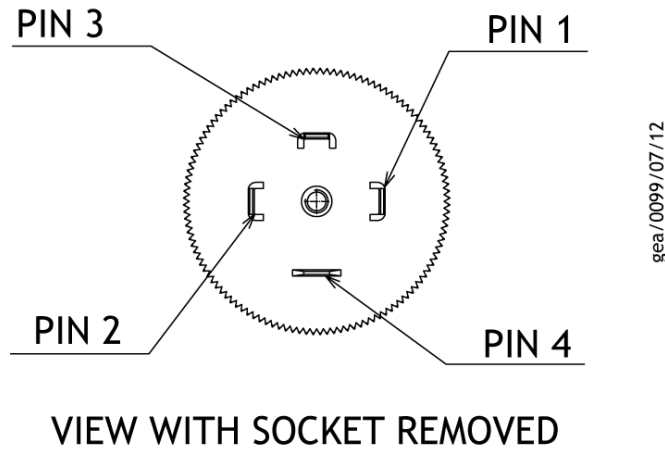

If connection using an FCC68 connector is preferred, the ASG2 adapter cable may be used and the pin allocations are as shown in Figure 4.

Pin number	Use
1	Electrical supply positive voltage
2	Electrical supply common
3	Pressure measurement output signal
4	Gauge identification signal
5	Signal common
6	No connection
7	No connection
8	No connection

Figure 4 - Pins on the ASG2 adapter cable socket

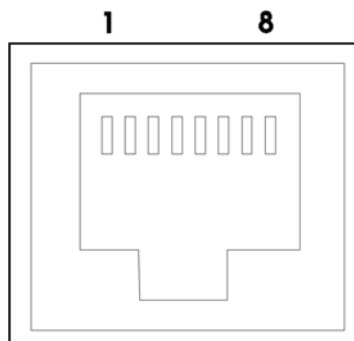

Schematic diagrams of the recommended electrical connections to the ASG2 are shown in Figure 5 and 6.

Figure 5 - Schematic diagram of typical electrical connections using 4 pin DIN connector

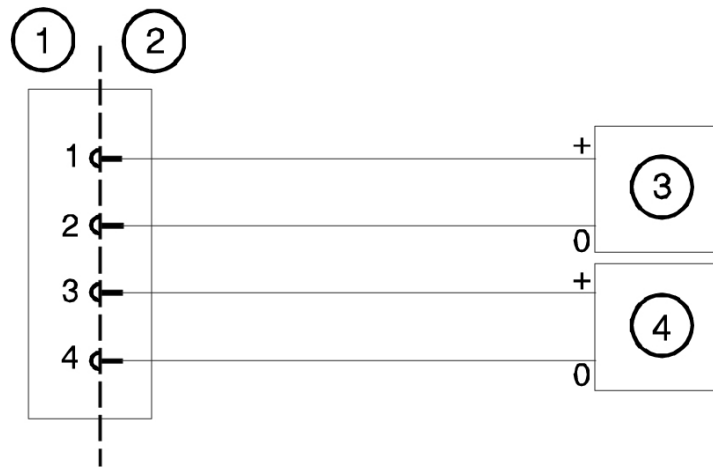

1. ASG2 electrical connector socket
2. Cable electrical connector plug
3. Electrical supply
4. Voltmeter

Figure 6 - Schematic diagram of typical electrical connections using the ASG2 adapter cable

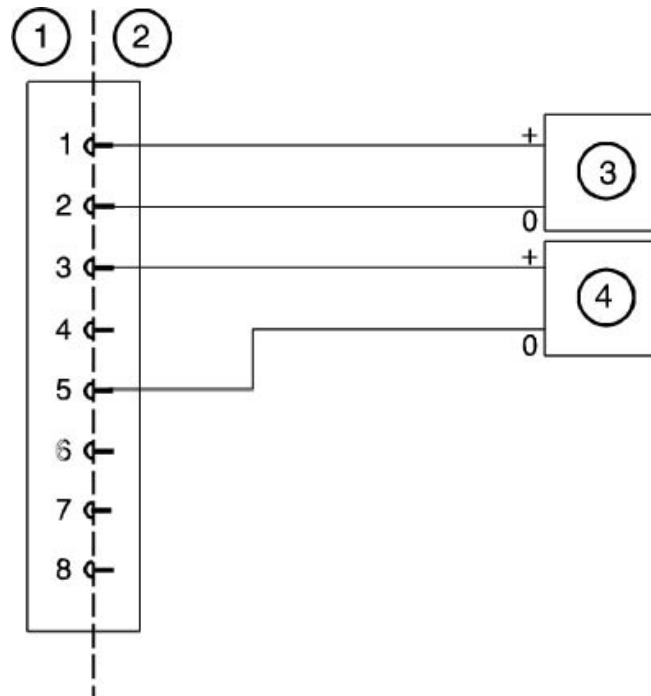

1. Adapter cable electrical connector socket
2. Cable electrical connector plug
3. Electrical supply
4. Voltmeter

This page has been intentionally left blank.

4 Operation

4.1 Pressure measurement

For most accurate pressure measurement the procedure in [Section 5.1](#) should be used to zero the gauge.

If you connect the ASG2 to an Edwards controller, the pressure measured by the ASG2 is shown on the display.

If you connect the signal output of the ASG2 to a voltmeter, convert the measured voltage to the corresponding pressure value using the following formula:

$$\text{Pressure} = \frac{\text{Full scale pressure}}{10} \times \text{Voltage}$$

This page has been intentionally left blank.

5 Maintenance

5.1 Zero adjustment

All diaphragm type gauges can exhibit a small drift in zero as a result of frequent cycling, over pressuring or contamination. This can be corrected by carrying out a zero adjustment.

To zero the ASG2, first evacuate the system to a pressure whose value is insignificant when compared to the required measuring accuracy. Table 1 suggests the pressures that should be achieved for zeroing to give maximum accuracy.

Once the zeroing pressure has been achieved the ASG2 pressure display should be adjusted to zero. This can be done using the zero setting potentiometer which is located within the ASG2 enclosure. The second potentiometer is for setting the gauge span and should not be adjusted without appropriate calibration equipment.

Referring to Figure 7, in order to access the zero and span potentiometers unscrew the DIN connector and remove it from the gauge. Unscrew the retaining ring and carefully remove the mating half of the DIN connector from the back of the gauge. The potentiometers are now accessible inside the gauge enclosure. The DIN connector can be reconnected to the gauge whilst the zero/span adjustment is performed.

If the ASG2 is used with an Edwards Controller then the zero adjustment can be made at the display rather than at the gauge head if this is more convenient (refer to the Controller's instructions for details).

Table 1 - Zeroing pressure

Transducer Full Range (mbar)	Zeroing Pressure (mbar)
2000	< 0.02
1000	< 0.01

Figure 7 - Zero and span setting detail

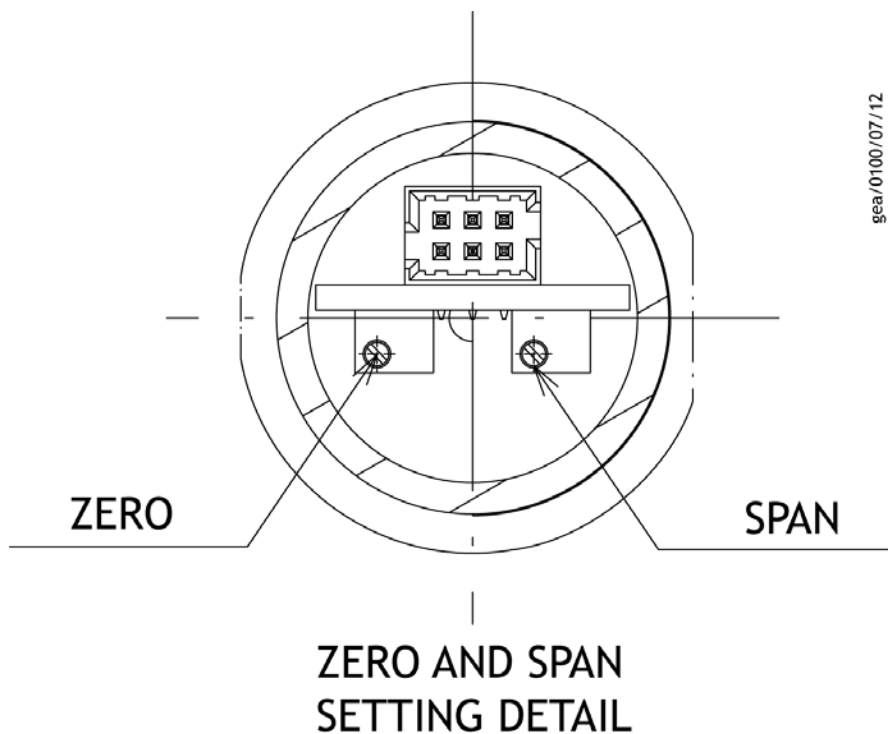

5.2 Cleaning

If the gas being measured contains oil vapour or other condensable products, the diaphragm may periodically become contaminated which may cause shifts in both zero and span. Any clean solvent that is compatible with stainless steel 316L and Hastelloy C276 may be used to dissolve the condensate and flush out the pressure inlet port.

Note: Do not use any ultrasonic procedure in cleaning the gauge since that may damage the unit.

6 Storage and disposal

6.1 Storage

Return the ASG2 to its protective packaging and store the ASG2 in clean dry conditions until required for use. Do not exceed the storage temperature conditions specified in [Section 2](#).

When required for use, prepare and install the ASG2 as described in [Section 3](#).

6.2 Disposal

Dispose of the ASG2 and any components safely in accordance with all local and national safety and environmental requirements.

Alternatively, you may be able to recycle the ASG2 and/or cables; contact Edwards or your supplier for advice (also see below).

The ASG2 and associated cables are within the scope of the European Directive on Waste Electrical and Electronic Equipment, 2002/96/EC. Edwards offers European customers a recycling service for the ASG2/cables at the end of the product's life. Contact Edwards for advice on how to return the ASG2/cables for recycling.

Particular care must be taken if the ASG2 has been contaminated with dangerous process substances.

This page has been intentionally left blank.

7 Spares and accessories

7.1 Introduction

Edwards products, spares and accessories are available from Edwards companies in Belgium, Brazil, Canada, France, Germany, Great Britain, Hong Kong, Italy, Japan, Korea, Switzerland, U.S.A, and a world wide network of distributors. The majority of these centres employ Service Engineers who have undergone comprehensive Edwards training courses.

When you maintain this Edwards product, we recommend you use only Edwards maintenance and service kits.

Order spare parts and accessories from your nearest Edwards company or distributor. When you order, please state for each part required:

- Model and Item Number of your equipment
- Serial number (if any)
- Item Number and description of part

7.2 Accessories

The adapter cable for use with the Edwards Active Gauge Controllers or Active Digital Displays is:

ASG2 adapter cable	0.5 m	D400-03-160
--------------------	-------	-------------

There are different lengths of cable to connect from the Edwards ASG2 to the adapter cable. They are as follows:

Cable length		Item Number
0.5 m	18 inches	D400-01-005
1 m	3 feet	D400-01-010
3 m	10 feet	D400-01-030
5 m	15 feet	D400-01-050
10 m	30 feet	D400-01-100
15 m	50 feet	D400-01-150
25 m	80 feet	D400-01-250
50 m	150 feet	D400-01-500
100 m	325 feet	D400-01-999

This page has been intentionally left blank.

This page has been intentionally left blank.

This page has been intentionally left blank.

Return the equipment or components for service

Before you send your equipment to us for service or for any other reason, you must send us a completed Declaration of Contamination of Vacuum Equipment and Components - Form HS2. The HS2 form tells us if any substances found in the equipment are hazardous, which is important for the safety of our employees and all other people involved in the service of your equipment. The hazard information also lets us select the correct procedures to service your equipment.

We provide instructions for completing the form in the Declaration of Contamination of Vacuum equipment and Components - Procedure HS1.

If you are returning a vacuum pump, note the following:

- If a pump is configured to suit the application, make a record of the configuration before returning the pump. All replacement pumps will be supplied with default factory settings.
- Do not return a pump with accessories fitted. Remove all accessories and retain them for future use.
- The instruction in the returns procedure to drain all fluids does not apply to the lubricant in pump oil reservoirs.

Download the latest documents from www.edwardsvacuum.com/HSForms/, follow the procedure in HS1, fill in the electronic HS2 form, print it, sign it, and return the signed copy to Edwards.

Note: *If we do not receive a completed HS2 form, we will not accept the return of the equipment.*

