



STRATAVAC 2018
OPERATION MANUAL



YOU MUST READ THIS MANUAL BEFORE USE

August 2022

Table of Contents

- 1. SECTION 1: DESCRIPTION AND PRINCIPLE OPERATIONS..... 3
- 2. SECTION 2: CONSTRUCTION 3
- 3. SECTION 3: UNPACKING AND INSPECTING..... 3
- 4. SECTION 4: INSTALLATION..... 5
- 5. SECTION 5: OPERATIONS 5
- 6. SECTION 6: FACTORY REPAIRS AND CALIBRATIONS..... 6
- 7. SECTION 7: UNDERSTANDING TORR..... 7
- 8. SECTION 8: ATTACHMENTS AND ILLUSTRATIONS..... 7
- 9. SECTION 9: TERMS OF USE, LIMITED WARRANTY & LIABILITY WAIVER..... 9

SECTION 1: DESCRIPTION AND PRINCIPLES OF OPERATION

The DigiVac STRATAVAC 2018 is a digital vacuum control instrument highly configurable and capable of driving multiple types of sensors (active, passive, and capacitance manometers).



Its 4 main operational uses are:

1. **Display Controller:** for 1-3 active and passive vacuum and pressure gauges
2. **Vacuum Controller:** capable of maintaining vacuum by either throttling a vacuum pump or bleeding air into a vessel
3. **Relay controller:** capable of turning on/off valves and other gauges based on vacuum level
4. **Internet Telemetry Device:** capable of both monitoring and alerting users

The DigiVac STRATAVAC has many applications from simple passive sensor monitoring to combining multiple sensors in order to create a wide range calibration standard that controls vacuum pump down. It uses a modular building block approach to build the most efficient configuration to achieve a task. For example, simply populate it with 2 passive driver cards and 2 chambers can easily be monitored from one device. By default, the StrataVac has a USB input that allows hardwire digital communication that can be used for logging or control. One of the great values of the StrataVac is it's extensive sensor compatibility. It works with most active gauges sold on the market today including Inficon, MKS and Pfeiffer cold cathode and Pirani gauges. The StrataVac was built for

control and telemetry from the ground up, so configuring USB, wifi or internet connectivity is a breeze. Below we illustrate 4 common configurations:

Configuration	Why	Example Applications
StrataVac with one gauge card + one gauge	<ul style="list-style-type: none"> • Simple and safe way to power and read a gauge • Easily connect gauge to computer for USB logging • Output Options: actual gauge analog output or options to select a linear output 	A University student is putting together a coating system and needs to measure and record high vacuum data.
StrataVac with two gauge cards + two capacitance manometers	<ul style="list-style-type: none"> • Simple and safe way to power and read a gauge • Easily connect multiple gauges to computer via a single USB cable • <i>Ability to combine 2 capacitance manometers to yield one continuous pressure for the combined ranges</i> 	A Firm performing calibrations wants to avoid confusion dealing with different pressures ranges and prefers one combined range.
StrataVac with one gauge card, gauge, throttle valve controller card, and throttle valve	<ul style="list-style-type: none"> • Enables vacuum pressure control using a standard solenoid valve for throttling pump suction • User can maintain vacuum levels or change levels • <i>Extends life of pump by enabling pump to run closer to its base pressure</i> 	A botanical processor wants to maintain specific pressure levels in a vacuum oven of about 10 Torr to avoid removing target terpenes while still removing only water.
StrataVac with one gauge card, gauge, bleed valve controller card and VacStable bleed valve with wireless feature	<ul style="list-style-type: none"> • Enables vacuum pressure control using a small bleed valve • User can maintain vacuum levels or change those levels, and its PID response • <i>You can surf over to your gauge, adjust set points and view your process progress anywhere there is internet</i> 	In order to help a manufacturer control their freeze drying process better, they implement this StrataVac configurations to maintain 300 millitorr in batches to improve consistency, and will always be able to view process status from their cell phone

Versatility Within Your Reach

The StrataVac 2018 is configured with sensors based on the accuracy and range required to sense vacuum and display the pressure reading in user selectable units of: Torr, mbar, kilopascal or millitorr. The DigiVac StrataVac 2018 can be panel mounted or sit on a bench top. It has an

extensive support matrix that includes most capacitance manometers, active and passive gauges available from Lesker, Agilent, Inficon, MKS and Setra. A support matrix is available in Section 8.

In order to achieve this versatile functionality, the StrataVac has a modular building block approach that allows the user to select the hardware necessary for their particular application.

In general, a working StrataVac configuration consists of:

Basic StrataVac Controller: includes a bright white LED display, 4 configuration buttons, USB port, a 5 Volt analog output port and a 24 Volt power supply.

Configurable Options Chosen Based on Application Needs:

1. Between 1 and 3 active gauges or capacitance manometers
2. Between 1 and 3 standard 5 volt sensors, such as DigiVac's 775i
3. Between 1 and 3 passive gauges.
4. Up to 1 valve control card to control up to 2 valves for isolation or vacuum control, or to apply a bleed to maintain a vacuum level.
5. The ability to control up to 2 type "C" relays
6. A wireless Ethernet card that enables connecting to your gauge via http or telnet; and enables connectivity to the vacuumnetwork.org cloud monitoring service.

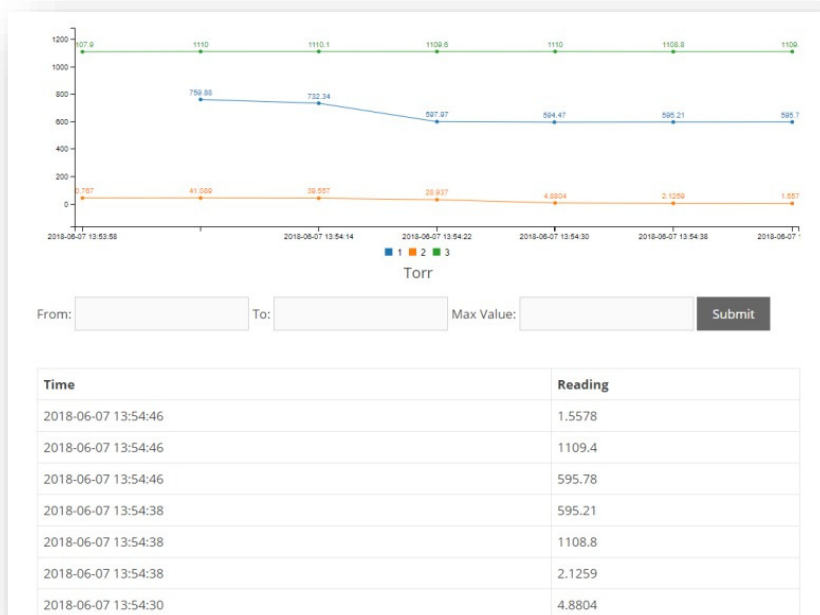

Consult the DigiVac website www.DigiVac.com for information about other DigiVac vacuum controllers and gauges.

SECTION 2: CONSTRUCTION

The StrataVac 2018 consists of the indicating and controlling instrument, the sensor configured, the sensor cable, the output interfaces and an international AC power adapter.

The instrument is housed in a rugged free-standing plastic enclosure. It can either be placed on a desktop or lab top surface, installed on a laboratory stand with optional lab mount, or can be panel mounted in a 1/8" DIN panel cutout.

SECTION 3: UNPACKING AND INSPECTING

After the instrument is received, it should be carefully unpacked and inspected for damage during shipment and to confirm that all components are present. The Display Unit warranty pertains only to the instrument, and does not cover losses in shipping.

Each StrataVac 2018 should come with:

- o Display Controller (black box)
- o 10' Sensor cable with modular plugs that mate with the ordered driver cards
- o Power Supply
- o Rubber feet and mounting hardware
- o Quick Start Guide

SECTION 4: INSTALLATION

The instrument should be located in a clean, dry environment for best results. The unit can be panel mounted with the hardware provided in a 1/8" DIN panel cutout (3.64" x 1.78" [92mm x 45 mm]).

Alternatively, the unit can be placed on a desktop by placing the 4 rubber feet included with your gauge on the underside of the unit. Lastly, the StrataVac can be mounted on a lab pole or lattice system using the optional pole clamp. The gauge tube cable should be identified by wire tags or markings specific to your environment.

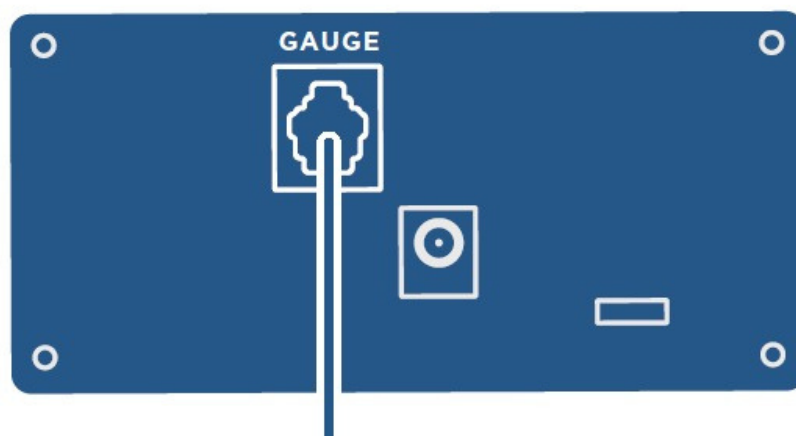

The Display controller can be connected to a computer with a standard micro-B USB cable. The software will automatically download and install. You can open a simple command window like putty and issue commands to read vacuum and assign set point values.

Important: Please use the supplied AC adapter with your Instrument. This adapter provides clean short protected power to protect and insure proper functioning of the internal circuitry.

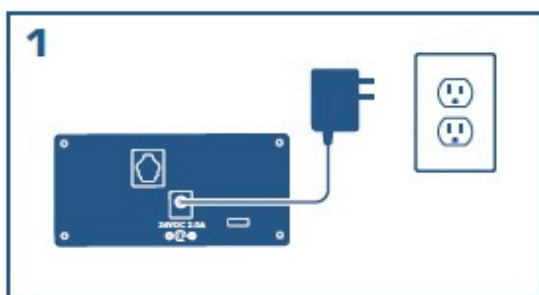

Connect power supply to unit, then connect to power supply to wall. Verify that StrataVac powers on

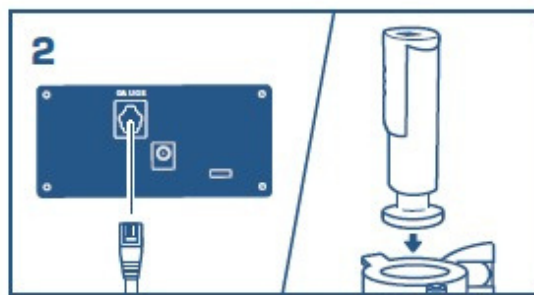

Connect sensor cable to the StrataVac & plumb the sensor into your vacuum system

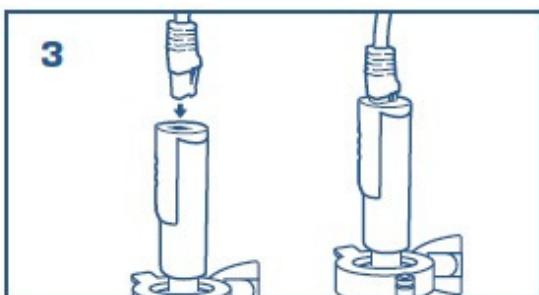

Connect the sensor cable to the sensor

As part of the DigiVac quality control process we configure the StrataVac controller for the purchased sensor(s) and/or Valve(s). No Field Configurations is necessary.

MENU TREE

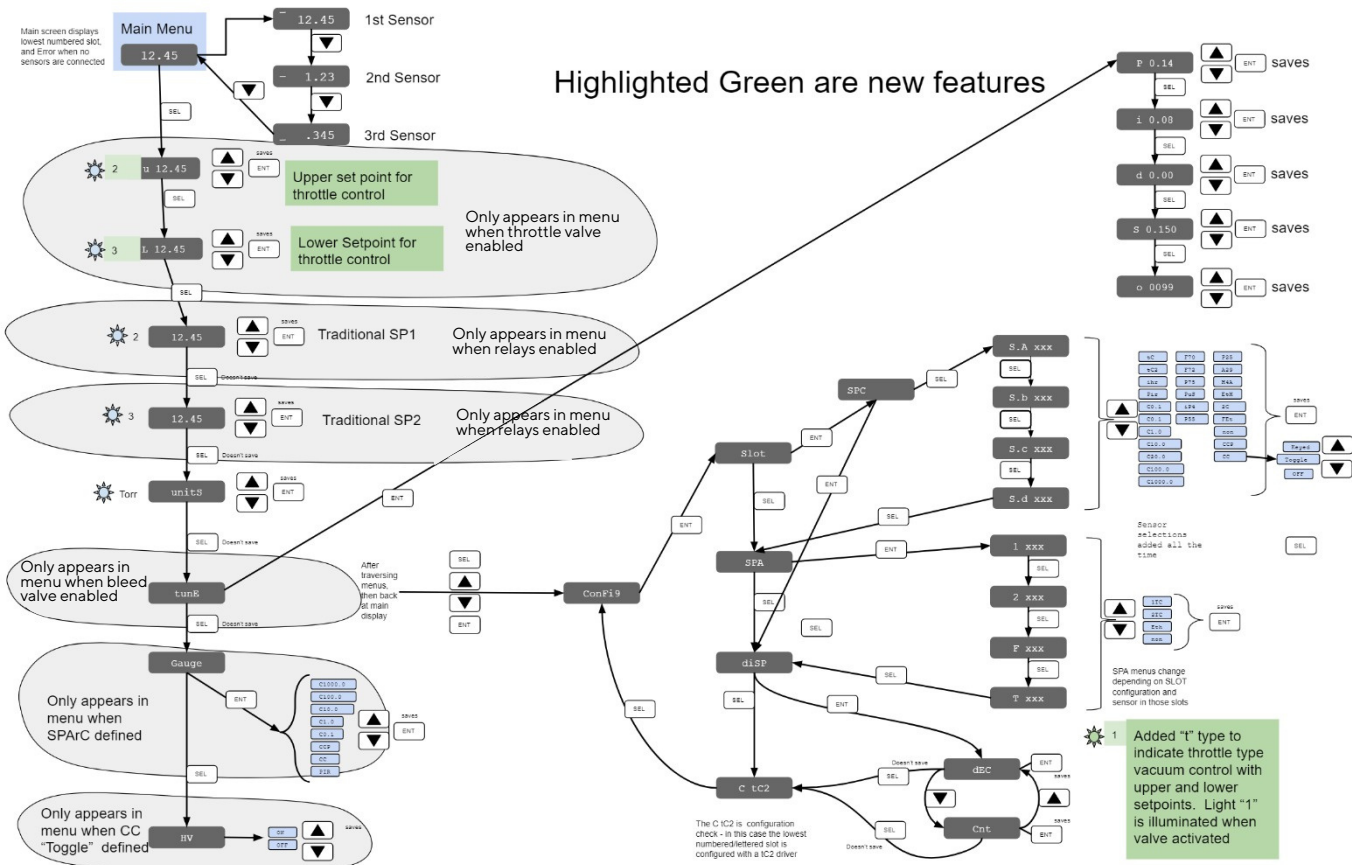

By default, all relays and valves are assigned to the first sensor card (the card in the lowest slot). The unit comes pre-configured to function properly from a hardware perspective. In some instances a user may change the active gauge driver if they want to use a different sensor with the StrataVac. Please contact tech support for complete instructions on re-configuring your gauge with a new sensor or to change valve assignment.

Most commonly used configuration changes are available from the main menu:

- Changing which sensor is currently displayed on the LED screen
- Changing the measurement units
- Enabling the high vacuum excitation of cold cathode gauges (when cold cathode gauges are configured)
- Changing relay set points when configured
- Changing upper and lower set points for valve control
- Changing S and PID tuning parameters when bleed valve control selected

CONFIGURATION

The StrataVac can have one, two or three sensors configured. These sensors may be individually viewed.

Note: DigiVac pre-configures and calibrates the purchased sensors to the controller at NIST Standards. To ensure the StrataVac Controller meets our stated accuracy specifications, DigiVac recommends annual calibration

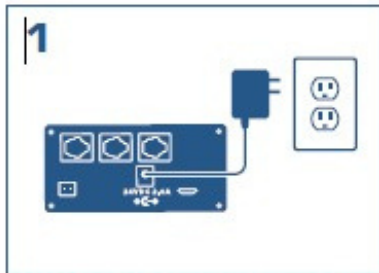

1
Connect power supply to unit, then connect to power supply to wall. Verify that StrataVac powers on.

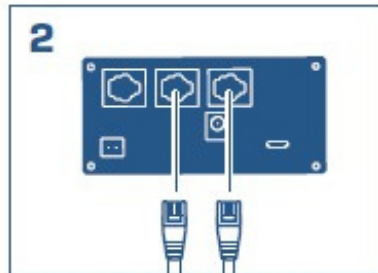

2
Connect the sensor cables to the StrataVac.

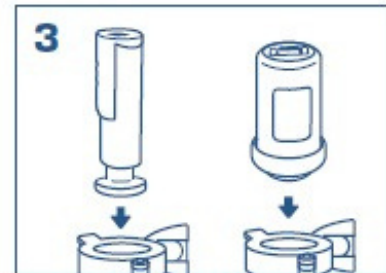

3
Plumb the sensors into your vacuum systems.

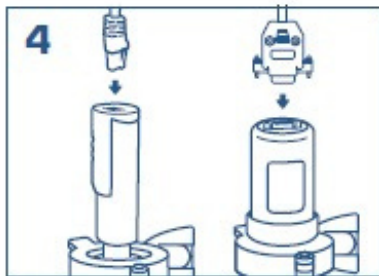

4
Connect your sensor cables to the sensors.

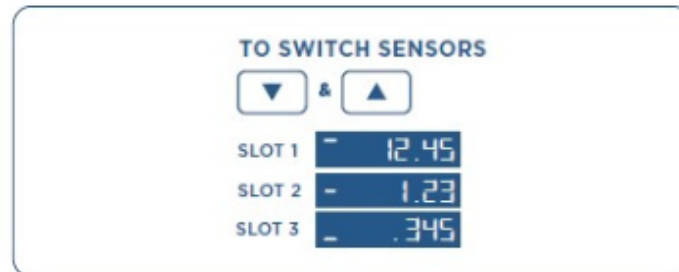

Additionally, in certain cases sensors may be combined in order to achieve a combined virtual sensor composed of 2 or more sensors.

Capacitance Manometer Combination Options	
Combination Driver	Sensors combined
2CM	0.1 Torr + 10 Torr
2CM	10 Torr + 1000 Torr
3CM	0.1 Torr + 10 Torr + 1000 Torr

The sensor in the lowest lettered slot (A, B, C, etc.) on the read of the unit is the sensor displayed by default. Simply use the up and down arrows to display other sensors. Below the display is showing the third sensor configured. Note once set to a particular sensor, the reading will maintain that particular sensor until it is changed by the user. At all times, all current sensor readings are available to their assigned relays, valves and set points; to the network and to USB.



SECTION 5: OPERATION

After installation, the Display Unit is ready for immediate operation. NEVER DISCONNECT SENSOR OR OUTPUT WIRES WHILE UNIT IS POWERED UP. Only connect and disconnect cables with the power to the unit unplugged. Make all connections to sensors and relay outputs with the power disconnected.

In cases where the system has contaminants (i.e. in metalizing and coating applications), it is often effective to isolate the sensor with a solenoid or manual valve when contamination is most active.



The Display Unit Controller can be easily set to the desired units at anytime:

1. Press the “sel” key three times during normal operation. The currently selected units will blink
2. Press the “ ” and “ ” to get to the desired unit.
3. Press “Ent” to complete your selection.

One of the units LEDs to the right of the LCD will always be lit during normal operation to indicate which pressure range the display is indicating.

The LED display will show one of 4 indications:

1. A number in decimal or scientific notation displaying the current indicated vacuum pressure
2. A dash in the upper middle or lower left digit showing whether the unit is displaying the current pressure from the first, second, or third sensor (in slot A, B, or C, respectively.)
3. “Error” indicating that the sensor is disconnected or not functioning
4. “Range” indicating that the sensor is out of it’s useful range. This can be overridden by putting the unit in raw counts mode.

To Use the StrataVac 2018 with relays:

Install the StrataVac and the sensor in the vessel closest to the pressure that you care about. Next, wire in the valves.

The set point connections are in the back of the unit. There are 2 rows of pins. The top row of pins is for set point 1, and the bottom row of pins is for set point 2. The top 3 pins are in the order:

1. Common – The common line of a switch
2. N.C. – Normally closed. This means that above the set point value there is a current path between the common and the N.C. terminal. Put another way the switch is “ON” between these 2 terminals. At the set point value and below (higher vacuum, lower pressure) the connection is open. Put another way, the switch is “OFF” between the common and the N.C. connection at higher vacuum (a lower pressure reading).
3. N.O. – Normally open. This means that above the set point value there is no current path between the common and N.O. connection. Put another way the switch is “OFF” between these 2 terminals. When the vacuum indication goes below the set point value (higher vacuum, lower pressure) the current path closes. Put another way the switch is “ON” between the common and N.O. connections at absolute pressure readings below the set point value.

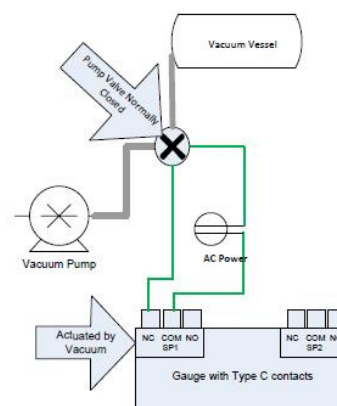
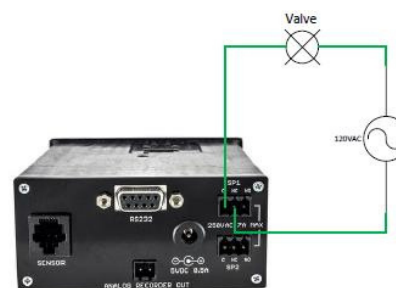

Take care to insure that the wire connections are made fast, and the voltage and current does not exceed 250V or 7A. If you need to control a device that draws more power (like a vacuum pump or heater), consider another relay in between the DigiVac output and the device to be controlled.

Below is a description of how relays act as a function of vacuum level.

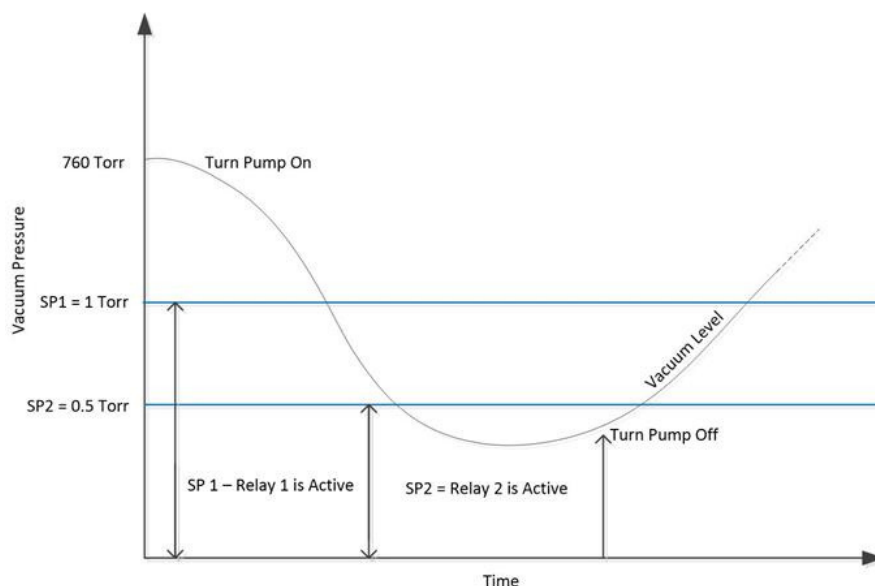

To Use the StrataVac 2018 as a Throttle Type Regulator:

1. Install valve between pump and vessel. Note the Valve in regulation mode is powered directly by the StrataVac, unlike standard relays (which require wiring to an AC or other power source)
2. Install sensor near the vessel
3. Set upper and lower set points
 - a. Click the “sel” button on the display until you see “U”
 - b. Press the up or down arrows until you are satisfied with your set point selection
 - c. Click “enter” when done
 - d. To set the lower set point, click the “sel” button on the display until you see “L”
 - e. Press the “sel” button again to view “L”
 - f. Repeat steps b and c
4. Observe control and adjust as necessary



To navigate to the upper set point, press Select (SEL) until you see “U” on the display.



Use the up/down arrows to change the set point. Once the desired set point is reached, press Enter (ENT) to save.



To navigate to the lower set point, press Select (SEL) until you see “L” on the display.



Repeat step two to set and save the lower set point.

The StrataVac vacuum regulator enables maintaining a vacuum pressure between two set points. The StrataVac directly powers a 24 volt valve (1 amp or less) by opening a valve until the lower set point is reached, then closing the valve allowing the system to bleed up

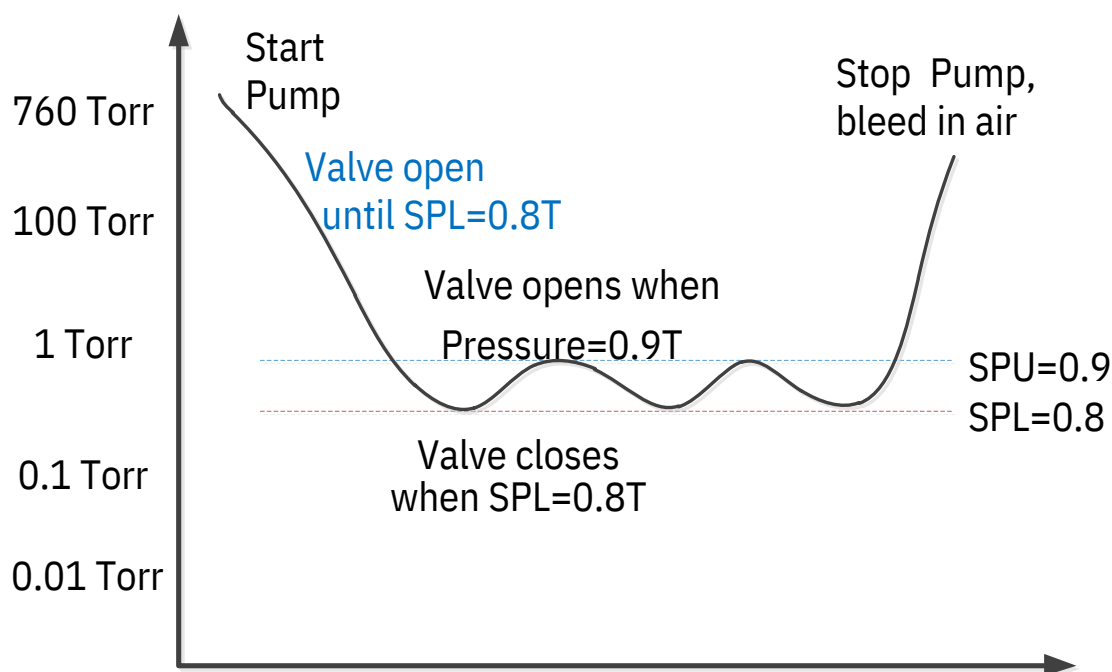

To Use the StrataVac 2018 as a Bleed Type Regulator:

The StrataVac can operate as a bleed type vacuum level controller when so configured. The solenoid valve is mounted as close to the vessel as appropriate, with the wires for the solenoid valve terminating on pins 1 & 2 of the 2 position VLC connector. Set the VLC set point by setting "S" in the tune menu to the desired vacuum level to be maintained. The StrataVac has been tested on vessels from 0.2 Liters to 50 Liters with good success. In many cases, you may not need to touch the PID tuning variables. In the event that the control out of the box doesn't work well, you can change the P, I and D variables to obtain a more desirable result.

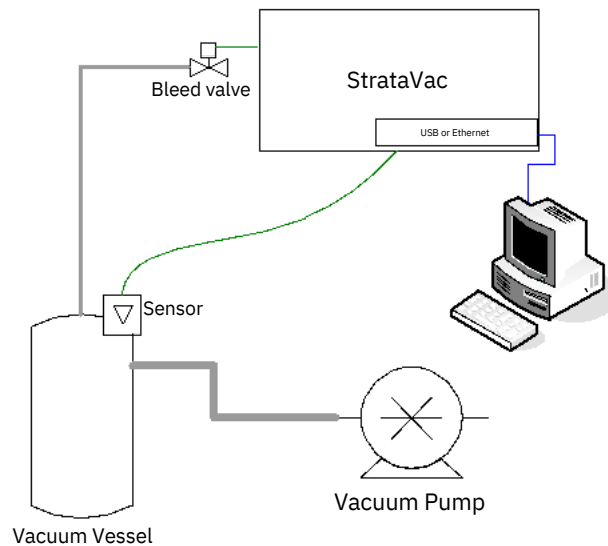

To get to the PID tuning variables, press the “SEL” button until you get to a screen that says “tune”, then hit “ENT”

- The first variable is “S” which is what you would use to adjust the set point for VLC control.
- Hit “Sel” to the desired variable, either “P”, “I”, “D”, or “O”
- When the desired variable is displayed, Press the “ ” and “ ” to get to the desired value
- Press “ENT” when completed. Not pressing enter will result in no change of PID value.

PID overview:

PID control is largely used in industry, and refers to the variables in the control equation “proportional,” “integral,” and “derivative.” For a PID primer, refer to http://en.wikipedia.org/wiki/PID_controller

- **P:** is implemented as a proportional gain (not as a proportional band). Larger values of P yield smaller error with less stability. The range is 0.01 to 99.99 with units of %.
- **I:** is also a gain. Larger values of I will yield faster response with less stability. The range is 0.00 to 99.99 with units resets/minute
- The **D** Range is 0.00 to 99.99 with units of minutes.
- **O:** is a feed forward term, and is especially helpful with smaller vessels. The range is from 0-99, where O=99 is traditional PID without the feed forward effect.

Here are the recommended PID tuning steps:

1. To Start

- a. Start with $P=0.14$, $I = 0.08$, $d=0$ $S=$ Set Point (1 Torr default), $O=0030$
- b. Increase “O” in increments of 5 until the vacuum level is maintained at $\frac{1}{2}$ Set Point
- c. Increase “P” until oscillations observed at about 10% of average reading (not Set Point.. the reading will likely still be lower than set point)
- d. Set $P=P/2$ (half the oscillation value of “P” obtained above)
- e. Start with $I=P/4$ (at this point the vacuum level should be approaching the set point)

2. Tuning

- a. If oscillations are greater than desired, decrease “P” 10-20% at a time
- b. If Vacuum Level is less than the set point, increase I in increments of 20% until convergence at the set point

3. Rules of thumb

- a. If the vacuum level is below the desired set point with maximum values of P & I, then increase “O”
- b. If greater than preferred oscillations are occurring when $I>P$, try setting $I=P$
- c. If greater than preferred oscillations are occurring about a set point and $P<1$, reduce “O”

Communication: USB Connectivity

StrataVac has the ability to display vacuum readings on a desktop in real time. To view your vacuum pressures on your desktop, you first must download [PuTTY](#). Once the software is installed on your computer, follow the instructions below.

1. Go to your device manager and review your COMM port

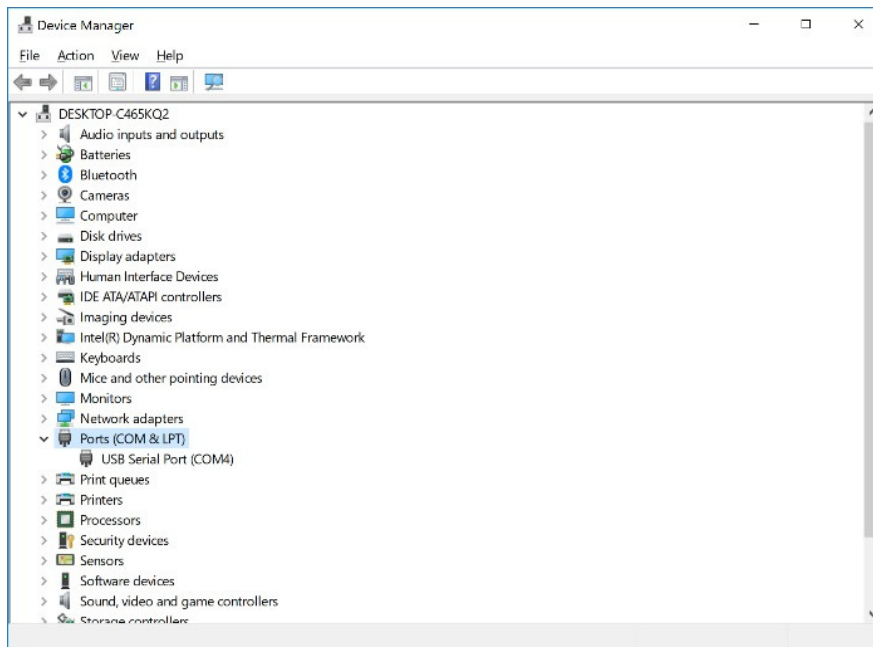

2. Open PuTTY on your desktop

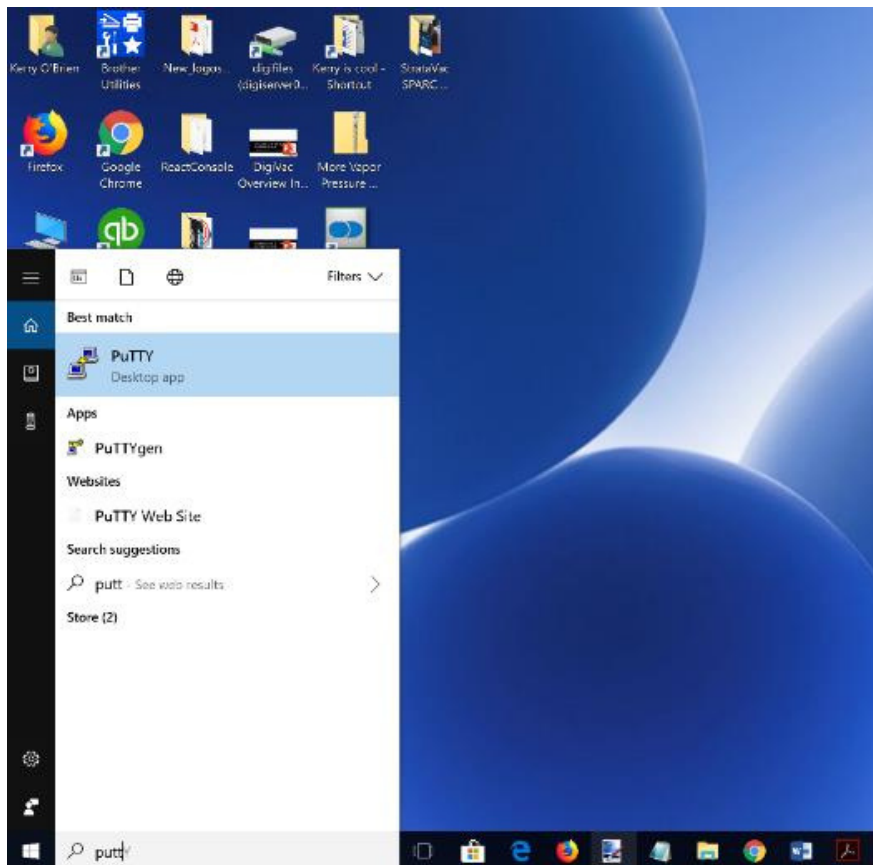

3. Select “serial” as your connection type and set the speed to 115200

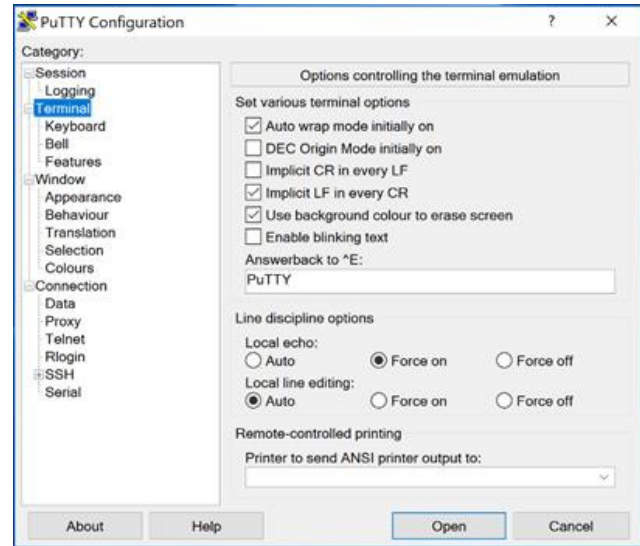
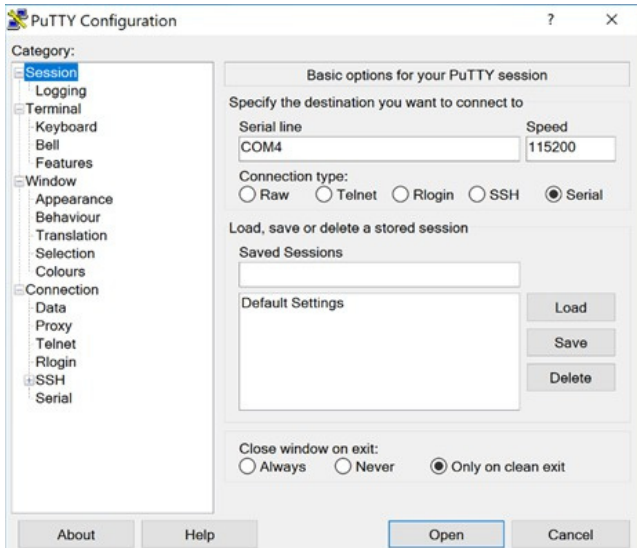

4. Under “Category” on the left, select “terminal” then select various terminal options. Still on this screen, select “force on” as the Local echo line display. Click open.

The screenshot shows a PuTTY terminal window titled '192.168.0.30 - PuTTY'. The terminal displays a list of vacuum data points in a grid format:

```
VAC1=388.0400 VAC2=759.4022 VAC3=750.2184 SPU=5.1400 SPL=2.0700
VAC1=389.0471 VAC2=759.4535 VAC3=746.6561 SPU=5.1400 SPL=2.0700
VAC1=388.8254 VAC2=759.3777 VAC3=757.1195 SPU=5.1400 SPL=2.0700
VAC1=388.9439 VAC2=759.3167 VAC3=758.1550 SPU=5.1400 SPL=2.0700
VAC1=389.2839 VAC2=759.3090 VAC3=761.3547 SPU=5.1400 SPL=2.0700
VAC1=389.5392 VAC2=759.3141 VAC3=760.0190 SPU=5.1400 SPL=2.0700
VAC1=389.6327 VAC2=759.3843 VAC3=758.7595 SPU=5.1400 SPL=2.0700
VAC1=389.9755 VAC2=759.2949 VAC3=759.7053 SPU=5.1400 SPL=2.0700
VAC1=390.0746 VAC2=759.3066 VAC3=757.0053 SPU=5.1400 SPL=2.0700
VAC1=390.7358 VAC2=759.4776 VAC3=759.0011 SPU=5.1400 SPL=2.0700
VAC1=390.6849 VAC2=759.4129 VAC3=757.2856 SPU=5.1400 SPL=2.0700
VAC1=390.4573 VAC2=759.2279 VAC3=760.3283 SPU=5.1400 SPL=2.0700
VAC1=391.0159 VAC2=759.3619 VAC3=773.2523 SPU=5.1400 SPL=2.0700
VAC1=391.1296 VAC2=759.3077 VAC3=768.7596 SPU=5.1400 SPL=2.0700
VAC1=391.5724 VAC2=759.3403 VAC3=770.7045 SPU=5.1400 SPL=2.0700
VAC1=391.4987 VAC2=759.2391 VAC3=764.3661 SPU=5.1400 SPL=2.0700
VAC1=391.7511 VAC2=759.2485 VAC3=771.5813 SPU=5.1400 SPL=2.0700
VAC1=392.4893 VAC2=759.3641 VAC3=765.1457 SPU=5.1400 SPL=2.0700
VAC1=392.5623 VAC2=759.2724 VAC3=764.1800 SPU=5.1400 SPL=2.0700
```

5. View your vacuum on your desktop!

StrataVac "Cheat Sheet"

VAC? Get vacuum reading.
Vac1? Get vacuum reading of sensor in first slot (ex: slot A)
Vac2? Get vacuum reading of sensor in second slot (ex: slot B)
Vac3? Get vacuum reading of sensor in third slot (ex: slot C)

M? Get mode setting.
 Returns "M=A" for automatic mode,
 Returns "M=M" for manual mode.

M=A Set mode to automatic.
M=M Set mode to manual
M=D Set to diagnostic mode

T? Get timing setting. This is how frequently we will burp out data in automatic mode, in seconds.

T=.25 Set data burp rate to Four times per second.
T=30 Set data burp rate to twice per minute.
T=60 Set data burp rate to once per minute.
T=600 Set data burp rate to once per 10 minutes.

Accepted range for T is .25 to 600

U? Get units setting.
 Responds appropriately with "U=0", "U=1", or "U=2"

U=0 Set units to Torr
U=1 Set units to mBar
U=2 Set units to kPa

P? Get P term
P=2.35 Set P term

I? Get I term
I=16.789 Set I term

D? Get D term
D=8.087 Set D term

O? Get O term
O=99 Set O term

S? Get S term
S=.82 Set S term

SP1? Get SP1 setting.
SP1=123.456 Set SP1

SP2? Get SP2 setting.
SP2=34.506 Set SP2

V? Get the Version, such as K11D13

SECTION 6: FACTORY REPAIRS AND CALIBRATIONS

The vacuum gauge assembly is designed to provide years of trouble-free service, and the liberal internal use of plug-in components make it easily repairable. No field servicing of the unit is recommended, other than replacement of the gauge tube, but factory servicing and calibration are available at a nominal cost.

We are here to help: Phone: 732-765-0900

Email: sales@digivac.com

SECTION 7: UNDERSTANDING TORR

The Display Unit, and many similar instruments, are calibrated in microns or "millitorr." It is appropriate to discuss what microns are and to relate microns to other measures of pressure and vacuum.

Microns are not really a measure of vacuum at all, but rather of absolute pressure. It will be recalled that the pressure of the atmosphere is 14.696 or approximately 14.7 pounds per square inch at sea level. This pressure is due to the weight of all of the air in the earth's atmosphere above any particular square inch. This 14.696 psi is equivalent to the pressure produced by a mercury column of approximately 29.92 inches high or .76 meters (about 3/4 of a yard) or 760 millimeters of mercury. Atmospheric pressure varies greatly with altitude. It decreases approximately 1 inch of mercury per thousand feet of altitude. It also varies widely with local weather conditions. (Variations of one half inch in a single day are common.) The word vacuum means pressure lower than atmospheric or "suction," but, in describing negative pressure, the atmosphere is only a satisfactory reference if we are dealing with values of vacuum down to about 27 inches of mercury. Below that, it is much more useful to talk in terms of absolute pressure, starting from absolute zero. The Display Unit and all similar instruments do just this.

One TORR, a commonly used unit, is an absolute pressure of one millimeter of mercury. A millitorr is equal to one thousandth of a TORR. A MICRON is the same as a millitorr. The full scale reading of a DigiVac is 1999 microns and is equivalent to 1.999 TORR of approximately 2/760 of atmospheric pressure. This is less than .1 inches of mercury, and less than .05 PSI.

SECTION 8: ATTACHMENTS AND ILLUSTRATIONS

TYPES OF SENSORS SUPPORTED

Description	Manufacturer	Supported Part Numbers	Sensor Interface	Number supported	Required StrataVac Card	Required Adapter	Driver
KJLC Pirani	Lesker	PIR-xx-x	FCC68	3	AG-CM STR	none	Pir
KJLC Cold Cathode	Lesker	CCG-xx-x	FCC68	3	AG-CM STR	none	CC
KJLC Cold Cathode Pirani	Lesker	CCPG-xx-x	FCC68	3	AG-CM STR	none	CCP
PVG-500 Pirani	Agilent	PVG500xxxxx	FCC68	3	AG-CM STR	none	PV5
PVG-550 Pirani	Agilent	PVG550xxxxxxx	FCC68	3	AG-CM STR	none	P55
IKR251 Cold Cathode	Pfeiffer	PT R25 500	Hirschmann	3	AG-CM STR	CM-HIR STR	ihr
FRG-700 Inverted Magnetron Pirani	Agilent	FRG70xxxxx	FCC68	3	AG-CM STR	none	F70
PCG-750 Pirani Capacitance Diaphragm Gauge	Agilent	PCG75xxxxxxxx	FCC68	3	AG-CM STR	none	P75
PKR251 Inverted Magnetron Pirani	Pfeiffer	PT R26 000	Hirschmann	3	AG-CM STR	CM-HIR STR	P25
MPG400/401 Inverted Magnetron Pirani	Inficon	351-xxx	FCC68	3	AG-CM STR	none	iP4
PSG5xx ATM to Medium Vacuum Gauge	Inficon	350-xxx	FCC68	3	AG-CM STR	none	Pir

Gemini MA G500	Inficon	3MAx-xxx-x0xQ	FCC68	3	AG-CM STR	none	CC
----------------	---------	---------------	-------	---	-----------	------	----

Cold Cathode							
Gemini MPG500 Cold Cathode Pirani	Inficon	3MBx-xxx-x0xP	FCC68	3	AG-CM STR	none	CCP
PCG550 Pirani Capacitance Diaphragm Gauge	Inficon	3PCx-01x-000x	FCC68	3	AG-CM STR	none	P75
MX4A Convection Gauge	Televac	all	DB15	3	AG-CM STR	AG DB15-MX-STR	coming soon
MX2A Thermocouple	Televac	all	DB15	3	AG-CM STR	AG DB15-MX-STR	coming soon
531 or 536 thermocouple vacuum gauge tube	Agilent	SEN-53x-xxxx	US-08	3	531-STR	none	TC
902B Absolute Piezo	MKS	902B-xx08x	FCC68	3	AG-CM STR	none	coming soon
Sky Ambient Capacitance Manometer	Inficon	3xx-00x	DB15	3	AG-CM STR	CM DB15-STR	CM
Sky 45 Capacitance Manometer	Inficon	3CC1-x5x30x	DB15	3	AG-CM STR	CM DB15-STR	CM
Sky 100 Capacitance Manometer	Inficon	3CD1-x5x-230x	DB15	3	AG-CM STR	CM DB15-STR	CM
Sky 200 Capacitance Manometer	Inficon	3CF1-x5x-2300	DB15	2	AG-CM STR	CM DB15-STR	CM
Stripe Capacitance Manometer	Inficon	3CC9-x5x-2380	DB15	3	AG-CM STR	CM DB15-STR	CM
626 Capacitance Manometer	MKS	626Cxxxxyz	DB15	3	CM-STR DS	CM DB15-STR	CM
AA01A Capacitance Manometer	MKS	AA01AxxTxxx3x0 0 xxx	DB15	3	AG-CM STR	CM DB15-STR	CM

722B Capacitance Manometer	MKS	722BxxTxx2FA	DB9	3	AG-CM- STR	CM-DB9- STR	CM
730B Capacitance Manometer	Setra	730G-xxxx-A-xx 2C-D9-X	DB9	3	AG-CM STR	CM-DB9- STR	CM
Porter Capacitance Manometer	Inficon	3CAx-x5x-0000	FCC68	3	AG-CM STR	none	CM
CDG500	Agilent	CDG500Txxxxxx xx	DB15	3	AG-CM STR	CM DB15 - STR	CM

*note "x", "y", or "z" in part number means the part number can contain any option in that place

TYPES OF ACTIVE GAUGES SUPPORTED

StrataVac Name		Electrical Interface	Equation
PIR	PVG500 Pirani Active Gauge	FCC68 (RJ45)	$p = 10^{((V-c)/1.286)}$ c=6.304
CCP	MPG 500 Cold Cathode Pirani Active Gauge	FCC68 (RJ45)	$p = 10^{(1.667 \times V-d)}$ d=11.46
CC	MAG 500 Cold Cathode Active Gauges	FCC68 (RJ45)	$10^{(0.75 \times (V-c))}$ c=12.826

SENSOR OPTIONS

STRATAVAC 2018 Sensor ID	Gauge Name	Description
0.1	0.1 Torr ambient capacitance diaphragm gauge	0.1 Torr gas independent gauge for high accuracy measurement
1	1 Torr ambient capacitance diaphragm gauge	1 Torr gas independent gauge for high accuracy measurement
10	10 Torr ambient capacitance diaphragm gauge	10 Torr gas independent gauge for high accuracy measurement
100	100 Torr ambient capacitance diaphragm gauge	100 Torr gas independent gauge for high accuracy measurement
1,000	1,000 Torr ambient capacitance diaphragm gauge	1,000 Torr gas independent gauge for high accuracy measurement
CC	Cold Cathode Gauge	Cold cathode inverted magnetron high vacuum gauge
CCP	Cold Cathode + Pirani Combination Gauge	Combination cold cathode inverted magnetron Pirani gauge
PiR	Pirani Gauge	Advanced digital Pirani gauge with stainless steel sensor cell

INFICON SKY CAPACITANCE MANOMETERS SUPPORTED

StrataVac Sensor ID	Electrical Interface	Description	Equation
0.1	*DB-15	0.1 Torr gas independent gauge for high accuracy measurement	$P=V/100$
1	*DB-15	1 Torr gas independent gauge for high accuracy measurement	$P=V/10$
20	*DB-15	20 Torr gas independent gauge for high accuracy measurement	$P=2 \times V$
50	*DB-15	50 Torr gas independent gauge for high accuracy measurement	$P=5 \times V$
10	*DB-15	10 Torr gas independent gauge for high accuracy measurement	$P=V$
100	*DB-15	100 Torr gas independent gauge for high accuracy measurement	$P=V \times 10$
1,000	*DB-15	1,000 Torr gas independent gauge for high accuracy measurement	$P=V \times 100$

*Requires ADP-DB15-STRC Adaptor

OTHER TYPES OF ACTIVE GAUGES SUPPORTED

StrataVac Name		Electrical Interface	Equation
523	***MKS 523C Cold Cathode Gauge	DB-9	$p = 10(2 \times V - 8)$
P25	MPG400/401 Cold Cathode Pirani Gauge	FCC68 (RJ45)	$p = 10(1.667 \times V - d) \quad d=11.46$

***Support with ADP-DB9-523-STR Adaptor

MKS CAPACITANCE MANOMETERS SUPPORTED

StrataVac Sensor ID	Electrical Interface	Description	Equation
1	**DB-9	722B 1 Torr gas independent gauge for high accuracy measurement	$P=V/10$
20	**DB-9	722B 20 Torr gas independent gauge for high accuracy measurement	$P=2 \times V$
50	**DB-9	722B 50 Torr gas independent gauge for high accuracy measurement	$P=5 \times V$
10	**DB-9	722B 10 Torr gas independent gauge for high accuracy measurement	$P=V$
100	**DB-9	722B 100 Torr gas independent gauge for high accuracy measurement	$P=V \times 10$
1,000	**DB-9	722B 1,000 Torr gas independent gauge for high accuracy measurement	$P= V \times 100$
0.1	*DB-15	A-Baratron AA01 0.1 Torr gas independent gauge for high accuracy measurement	$P=V/100$
1	*DB-15	A-Baratron AA01 1 Torr gas independent gauge for high accuracy measurement	$P=V/10$
20	*DB-15	A-Baratron AA01 20 Torr gas independent gauge for high accuracy measurement	$P=2 \times V$
50	*DB-15	A-Baratron AA01 Torr gas independent gauge for high accuracy measurement	$P=5 \times V$
10	*DB-15	A-Baratron AA01 10 Torr gas independent gauge for high accuracy measurement	$P=V$

100	*DB-15	A-Baratron AA01 100 Torr gas independent gauge for high accuracy measurement	$P=V \times 10$
1,000	*DB-15	A-Baratron AA01 1,000 Torr gas independent gauge for high accuracy measurement	$P= V \times 100$

*Requires ADP-DB15-STR Adaptor

**Requires ADP-DB9-STR Adaptor

SPECIFICATIONS

Specifications	
Power:	100-240VAC 50/60 Hz CE Rated
Vacuum Interface:	1/8" Male NPT or KF/NW
Sensor (length):	Dependent on sensor(s) installed
Range:	Dependent on sensor(s) installed
Units:	Order as: Torr, mBar, kPa
Mount :	1/8 DIN or Bench Top
Display:	0.40 inch high 6 digit red LED
Dimensions:	1.7"H x 3.52"W x 5.35" Deep
Controls :	7 amp, 250 Volt (If applicable)
Telemetry Options:	USB, Wifi

SECTION 9: TERMS AND CONDITIONS

TERMS OF USE, LIMITED WARRANTY & LIABILITY WAIVER

DigiVac Co. offers all of its products with the following terms and conditions and notices as follows. By accepting and/or using a DigiVac Co. product, you hereby acknowledge and agree to the following terms and conditions, and acceptance of these terms and conditions are a condition precedent to any purchase/sale agreement between you and DigiVac Co..

EXCLUSIVE OBLIGATION: The DigiVac Co. product you are purchasing has been designed for a specific use within a set of suitable operating conditions, as set forth in its User Manual, or as indicated otherwise by DigiVac Co.. Any use of the DigiVac Co. Product for any purpose or under any conditions, other than those specified, shall render any limited warranty void, and shall expressly invalidate any liability of DigiVac Co. for damages as a result of such misuse.

USER LIMITATION: You may not modify, copy, distribute, transmit, display, perform, reproduce, publish, license, create derivative works from, transfer, or sell, any information, software, products or services obtained from or created by DigiVac Co. to any third party, without the express written consent of DigiVac Co. to do otherwise. Any violation of this provision shall give rise to an indemnification of DigiVac Co. by you, for any third party claims arising out of such violation.

THIRTY (30) DAY LIMITED WARRANTY: All DigiVac Co. products are warranted against any manufactured defect for a period of thirty (30) days from date of purchase, unless such product is a custom-work for you and not a standard DigiVac Co. product. Any product qualifying as a custom-work shall not be warranted against any defects for any purpose, and your acceptance of such custom-work shall relieve DigiVac Co. of any liability for any purpose. WITH THE EXCEPTION OF THE LIMITED WARRANTY ABOVE, YOU AGREE ANY DIGIVAC Co. PRODUCT IS PROVIDED AS IS, EXCLUSIVE OF ANY WARRANTY, INCLUDING, WITHOUT LIMITATION, ANY IMPLIED WARRANTY OF MERCHANTABILITY, FITNESS FOR A PARTICULAR PURPOSE, NON-INFRINGEMENT, OR ANY OTHER WARRANTY, EXPRESSED OR IMPLIED.

LIMITATION OF LIABILITY: You agree and acknowledge, DigiVac Co. shall have no liability to you whatsoever for any direct, indirect, punitive, incidental, special consequential damages arising out of or connected with the use or misuse of its products. In particular, given the nature of DigiVac Co. products, you agree and acknowledge, under no circumstances whatsoever shall DigiVac Co. be liable to you for any consequential damages for damage to any non- DigiVac Co. product or service, arising from the failure, use or misuse of a DigiVac Co. product, including, but not limited to, any vacuum system, engine, vehicle, factory, or the like. In the event, a court of law with proper jurisdiction finds DigiVac Co. liable to you for any purpose, you agree and acknowledge DigiVac Co.'s maximum liability shall not exceed the purchase price of one unit of product giving rise to such liability, or \$250.00, whichever is greater.

ENTIRE OBLIGATION: These terms and conditions express the entire obligation of DigiVac Co. with respect to its products. If any part of these terms and conditions are deemed void, invalid, unenforceable or illegal, including, but not limited to, the warranty disclaimers, liability disclaimers and liability limitations set forth above, then the unenforceable clause or sentence may be disregarded with the remainder of these terms and conditions valid and enforced. In the event the unenforceable clause or sentence leaves a void in these terms and conditions, a provision closely matching the intent of the unenforceable provision should be deemed inherent within these terms and conditions, slightly modified to render such provision valid and enforceable.

GENERAL: These terms and conditions are governed by the laws of the State of New Jersey, USA. You hereby consent to the exclusive jurisdiction and venue of the Courts of New Jersey, in all disputes arising out of or relating to the use of this product. Use of this product is unauthorized in any jurisdiction that does not give effect to all provisions of these terms and conditions.

MODIFICATION OF TERMS AND CONDITIONS: DigiVac Co. reserves the right to change the terms, conditions, and notices under which their products are offered.